



*Union Special*  
INDUSTRIAL SEWING EQUIPMENT

## STYLES

36200A

36200B

36200X

36200AA

36200AB

36200AK

36200AX

---

---

CLASS 36200  
HIGH SPEED  
CYLINDER FLATSEAMER  
MACHINES

---

---

CATALOG NO.  
118L

THIRD EDITION

Catalog No. 118 L

INSTRUCTIONS

FOR

ADJUSTING AND OPERATING

LIST OF PARTS

STYLES

36200 A	36200 AA
36200 B	36200 AB
36200 X	36200 AK
36200 AX	

Third Edition

Copyright 1960, 1962

By

Union Special Corporation  
Rights Reserved in All Countries

**UNION SPECIAL CORPORATION**

INDUSTRIAL SEWING MACHINES

**CHICAGO**

Printed in U. S. A.

July, 1979

TABLE OF CONTENTS

CATALOG NO. 118 L

<u>GENERAL SALES INFORMATION</u>	<u>Page No.</u>
Introduction -----	2
Table of Contents -----	3
Identification of Machines -----	4
Application of Catalog -----	4
Description of Machine -----	4
Needles -----	4
Ordering Repair Parts -----	5
Illustrations (explanation) -----	5
Identifying Parts -----	5
Use Genuine Needles and Repair Parts -----	6
Terms -----	6
 <u>GENERAL SEWING INFORMATION</u>	
Threading and Oiling -----	6
Diagram for Threading and Oiling -----	7
Machine Adjuster's Information -----	8
Installation of Machine -----	9
Mounting the Machine -----	9
Machine Speed -----	9
Setting Up Thread Stand -----	9
Threading the Machine -----	9
Preferred Threads -----	9
Sequence of Threading -----	9
Unlocking the Stitch -----	10
Replacing the Needle -----	10
 <u>INSTRUCTIONS FOR SEWING ADJUSTMENTS</u>	
Needle to Looper Setting -----	11
Needle and Needle Bar -----	11
Alignment of Needles to Throat Plate -----	11
Timing of Needles in Relation to Looper -----	12
Instructions for Using Synchronizing Gauge No. 21227 CG -----	12
Looper Adjustment -----	13
Feed Adjustments -----	13
Feed Height -----	14
Rear Needle Guard Adjustment -----	14
Stitch Length -----	14
Differential Control -----	14
Presser Foot Adjustment -----	14
Adjustment of Trimming Knives -----	15
Needle Thread Adjustments -----	16
Looper Thread Adjustment -----	16
Cover Thread Adjustment -----	16
Adjustment of Tension Release -----	16
Sewing Plastic With Nylon Thread and Without the 36211 Retainer -----	17
 <u>EXPLODED VIEWS AND DESCRIPTION OF PARTS</u>	
Drive Unit, Belt Guard and Mounting Stud -----	18
Reference Number, Part Number and Description -----	19
Main Frame, Miscellaneous Covers, Bushings and Take-up -----	20
Reference Number, Part Number and Description -----	21
Needle Lever, Main Shaft, Crankshaft and Miscellaneous Oiling -----	22
Reference Number, Part Number and Description -----	23
Foot Lifter and Tension Parts -----	24
Reference Number, Part Number and Description -----	25
Detachable Head, Covers, Needle Bar and Needle Bar Head -----	26
Reference Number, Part Number and Description -----	27
Differential Feed Bar, Main Feed Bar and Feed Lift Eccentric Assembly -----	28
Reference Number, Part Number and Description -----	29
Feed Drive Assembly, Feed Rocker, Looper Avoid Link Ball Joints -----	30
Reference Number, Part Number and Description -----	31
Looper Rocker Shaft, Looper Drive and Knife Drive Parts -----	32
Reference Number, Part Number and Description -----	33
Differential Feed Control, Cylinder Covers and Bushings -----	34
Reference Number, Part Number and Description -----	35
Presser Bar and Presser Feet -----	36
Reference Number, Part Number and Description -----	37
Presser Foot Shoes for 36200 Machines -----	38
Reference Number, Part Number and Description -----	39
Thread Stand and Accessories -----	40
Reference Number, Part Number and Description -----	41
 NUMERICAL INDEX OF PARTS -----	 42-43
 <u>UNION SPECIAL SALES OFFICES</u>	
Domestic and Foreign Sales Offices -----	Back Cover

## IDENTIFICATION OF MACHINES

Each UNION SPECIAL machine carries a Style number which is stamped in the name plate on the machine. Style numbers are classified as standard and special. Standard Style numbers have one or more letters suffixed, but never contain the letter "Z". Example: "Style 36200 A". Special Style numbers contain the letter "Z". When only minor changes are made in a standard machine, a "Z" is suffixed to the standard Style number. Example: "Style 36200 AZ".

## APPLICATION OF CATALOG

This catalog applies specifically to the Standard styles of machines as listed herein. It can also be applied with discretion to some Special machines in this Class. References to direction, such as right, left, front, back, etc., are given from the operator's position while seated at the machine. Operating direction of handwheel is clockwise.

## DESCRIPTION OF MACHINES

Feed-Off-The Arm, High Speed, Medium Throw Machine, Four Needles and Retainer Abreast, One Looper, Dial Adjusted Differential Feed Control, Enclosed Automatic Lubricating System, Filter Type Oil Return Pump, Visual Sight Oil Action and Supply Gauges, Maximum Work Space in Front of Needles 8 Inches.

36200 A FLATSEAMER. Six threads for simultaneously trimming and flatseaming infants' panties, men's briefs and shorts and all similar knitted garments made of light to medium weight material, where seaming and closing elastic is necessary. Seam Specification 607-FSa-1.

36200 B FLATSEAMER. Six threads for simultaneously trimming and flatseaming underwear, children's knit sleepers or similar garments and all knitted fabrics made of light to medium weight material, where seaming and closing elastic is not necessary. Seam Specification 607-FSa-1.

36200 X TAPE-SEAMER. Five threads for joining and taping fronts of knit briefs in one operation. Seam Specification 607-LSp-4 (Mod.)

36200 AA Same as Style 36200 A, except prepared for Pedestal Installation.

36200 AB Same as Style 36200 B, except prepared for Pedestal Installation.

36200 AK Same as Style 36200 AA, except for changes in Packing List No. 1-P-626; Added (1) 21114 AG-6 Lead Eyelet, (1) 21233 AJ Lead Eyelet Bracket Connection. Removed (1) 1421 Handwheel, (1) 1421 A Stud.

36200 AX Same as Style 32600 X, except prepared for Pedestal Installation.

## NEEDLES

Each UNION SPECIAL needle has both a type number and size number. The type number denotes the kind of shank, point, length, groove, finish and other details. The size number, stamped on the needle shank, denotes the largest diameter of the blade measured in thousandths of an inch midway between the shank and the eye. Collectively, the type number and size number represent the complete symbol.

Selection of proper needle size should be determined by the size of the thread used. Thread should pass freely through the needle eye in order to produce a good stitch formation.

For best results, use only genuine UNION SPECIAL needles in the operation of these machines. They are packaged under our brand name, *Union Special*, which is backed by a reputation for producing highest quality needles for more than three-quarters of a century.

The recommended needles are Type 118 GKS, size 075/029 for Styles 36200 A, B, AA, AB and AK; size 080/032 for Styles 36200 X and AX. Type 118 GKS is a round shank, round point, extra short, double groove, struck groove, spotted, .060 inch diameter shank, chromium plated needle and is available in sizes 070/027, 075/029, and 080/032.

To have needle orders promptly and accurately filled, an empty package, a sample needle, or the type and size number should be forwarded. Use description on label. A complete order would read: "1000 Needles, Type 118 GKS, Size 075/029".

## ORDERING REPAIR PARTS

### ILLUSTRATIONS

This catalog has been arranged to simplify ordering repair parts. Exploded views of various sections of the mechanism are shown so that the parts may be seen in their actual position in the machine. On the page opposite the illustration will be found a listing of the parts with their parts numbers, description and the number of pieces required in the particular view being shown.

Numbers in the first column are reference numbers only, and merely indicate the position of that part in the illustration. Reference number should never be used in ordering parts. Always use the part number listed in the second column.

Component parts of sub-assemblies which can be furnished for repairs are indicated by indenting their descriptions under the description of the main sub-assembly. Example:

27	29478 CS	Feed Lift Eccentric Assembly -----	1
28	29103 T	Feed Lift Ecc. Assembly Ball Joint-----	1
29	22587 E	Screw-----	2
30	22894 W	Screw-----	1
31	22764	Screw-----	1
32	269	Nut, left thread-----	1
33	36244	Connecting Rod-----	1
34	18	Nut, right thread-----	1

It will be noted in the above example that the eccentric and bearing are not listed. The reason is that replacement of these parts individually is not recommended, so the complete sub-assembly should be ordered.

In those cases where a part is common to all of the machines covered by this catalog, no specific usage will be mentioned in the description. However, when the parts for the various machines are not the same, the specific usage will be mentioned in the description and, if necessary, the difference will be shown in the illustration.

At the back of the book will be found a numerical index of all the parts shown in this book. This will facilitate locating the illustration and description when only the part number is known.

### IDENTIFYING PARTS

Where the construction permits, each part is stamped with its part number. On some of the smaller parts, and on those where construction does not permit, an identification letter is stamped into distinguish the part from similar ones.

Part numbers represent the same part, regardless of catalog in which they appear.

**IMPORTANT! ON ALL ORDERS, PLEASE INCLUDE PART NAME AND STYLE OF MACHINE FOR WHICH PART IS ORDERED.**

## USE GENUINE NEEDLES AND REPAIR PARTS

Success in the operation of these machines can be secured only with genuine UNION SPECIAL Needles and Repair Parts as furnished by the Union Special Corporation, its subsidiaries and authorized distributors. They are designed according to the most approved scientific principles, and are made with utmost precision. Maximum efficiency and durability are assured.

Genuine needles are packaged with labels marked *Union Special*<sup>®</sup>. Genuine repair parts are stamped with the Union Special trademark, U S Emblem. Each trademark is your guarantee of the highest quality in materials and workmanship.

### TERMS

Prices are strictly net cash and subject to change without notice. All shipments are forwarded at the buyer's risk f. o. b. shipping point. Parcel Post shipments are insured unless otherwise directed. A charge is made to cover the postage and insurance.

### THREADING AND OILING INFORMATION

#### VIEWS AA AND BB:

Thread as indicated in illustration on opposite page, starting with #4, progressing to 3, 2, 1, 5, and 6 in order and passing needle threads UNDER the stitch unlocking spring at needle thread frame eyelet "G".

#### VIEW CC:

Close-up of tension post assembly. A, Tension Nut; B, Spring; C, Post; D, Disc, upper; E, Disc, lower; F, Post Slot.

Pass threads thru slots "F" in tension post "C", and between tension discs "D" and "E".

#### VIEW DD:

Close-up of looper thread and cover thread take-ups.

#### VIEW EE:

Close-up of needle thread sequence.

### OILING

Referring to illustration on opposite page, machine is filled at the caps "H" and "J". Oil capacity of Class 36200 is 2 ounces in bottom oil reservoir and 2.5 ounces in the top reservoir. Use a straight mineral oil, Saybolt viscosity of 90 to 125 seconds at 100° Fahrenheit. The level is checked at the two sight gauges "K" and "L", located on the right side of the main frame under the foot lifter lever and at the front of the cylinder, respectively. Maintain oil level between red lines of these gauges.

Automatic lubrication is featured with a continuously driven rotary pump. Flow of oil can be observed thru windows "M" and "N" in crank chamber cover and front top cover. When installing a new machine or starting one that has been idle for some time, priming may be necessary. To do so, remove the two plug screws "P", fill holes with recommended oil and replace screws BEFORE operating. If oil does not flow while machine is running, pump is inoperative.

Oil is drained from machine at two places, "Q" and "R". "R" is located below and back of drive pulley. Belt cover must first be removed. When replacing the screw at "Q" be sure the hole in the filter box, that the screw goes into, lines up with the hole in the bottom of the cylinder.

Occasionally, it is necessary to oil the linkage of the presser foot, the knife holder shank No. 36273 A, guide collar No. 36273 K and the various links and bearings of the presser foot lifting mechanism and thread tension release.

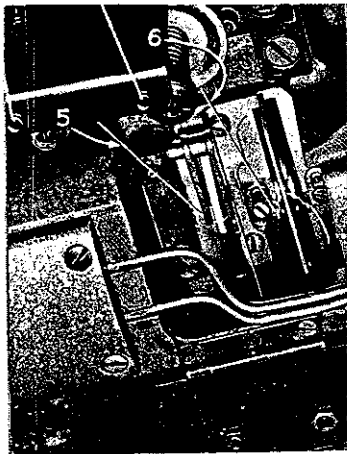

DD

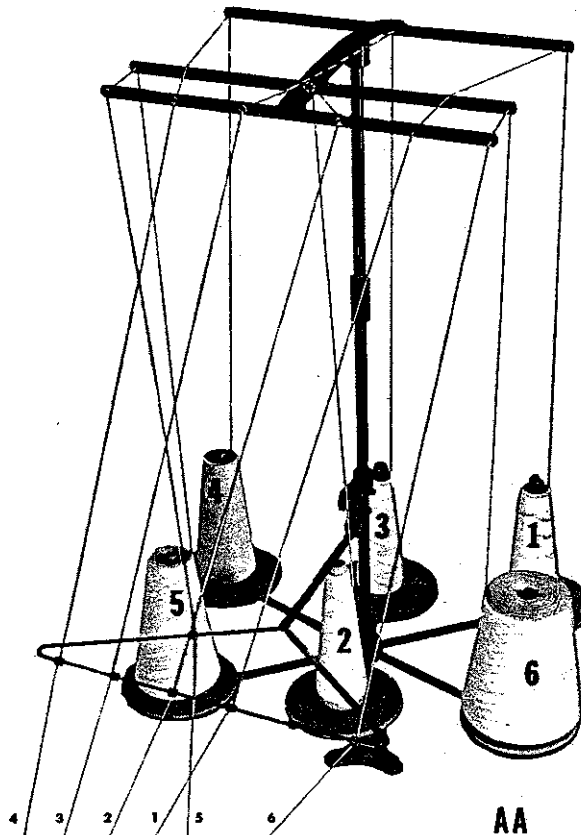

AA

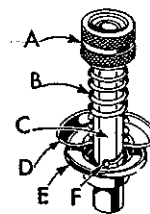
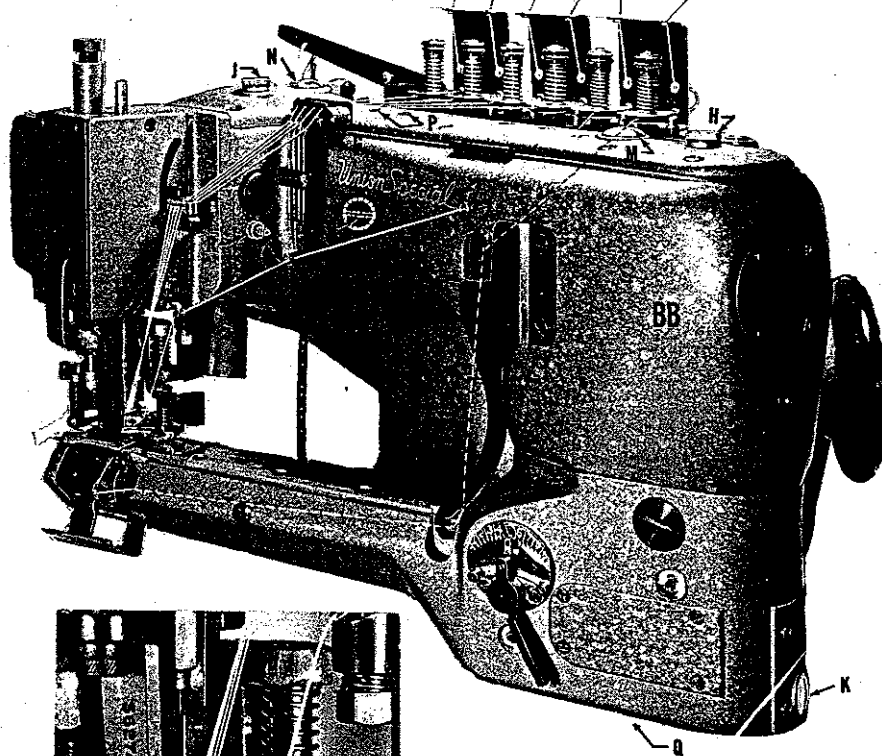

CC



EE

THREADING AND OILING DIAGRAM  
FOR STYLES 36200 A, B

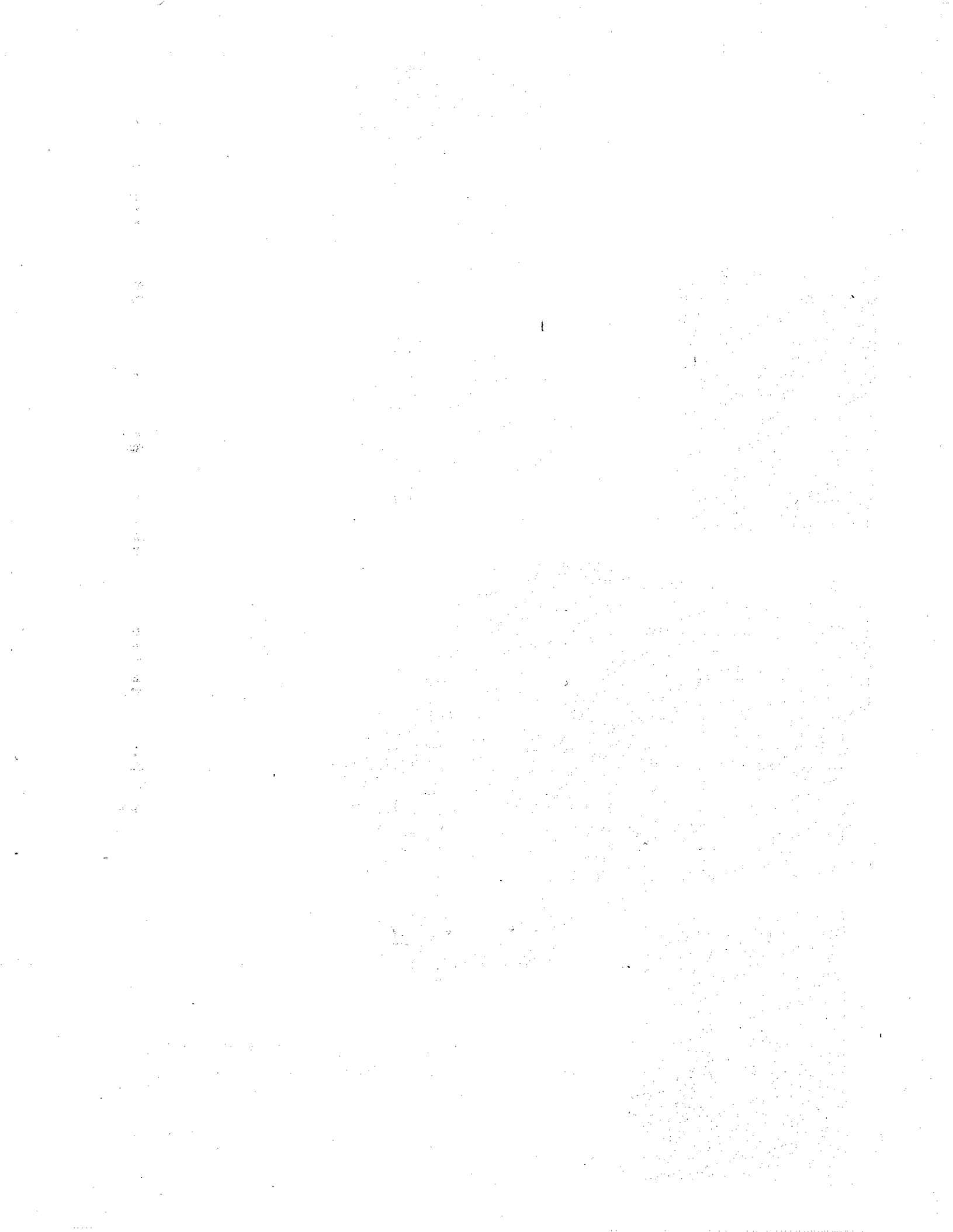



## INSTALLATION OF MACHINE

Where a power stand or line-shaft installation is desired, it is recommended that the machine be installed on a Union Special table board in order to obtain the benefits of isolated mounting, which is further improved by the use of Rubber Feet (#21371 JT), especially on wooden floors. However, if such a board is not available, a table board may be prepared to obtain isolation as shown on Planograph with template PL443.

It is more convenient to set up the Machine Drive Unit first and add Machine later. Insert the three Studs (#35895 R) into the base of the Drive Unit and tighten. Add one steel Washer (#21371 UE) and one Neoprene Corrugated Isolator (#660-275) in this order to each Stud and set Unit on table, Studs extending through holes. Add three Felt Sleeves (#660-161) on each Stud and press into holes. Assemble balance of parts per PL443. On left and front Studs, tighten first Nut with fingers only. Lock into position with second Nut. Tighten first Nut on rear Stud so that Drive Unit has about 1/32 less gap at rear. Lock into position with second Nut.

## MOUNTING THE MACHINE

Correct Screws for assembling Machine to Drive Unit are Allen Head Cap Screws 3/8 - 16 x 1 1/4 inch long (#22652 F-20) and are packed in small parts box. Freedom of screw body in hole permits Machine to be levelled before tightening securely. Place short Belt (#21261 M-210) first over Adjustable Pulley and then on Machine Pulley. Tighten Belt by turning flange of Adjustable Pulley clockwise to increase the pitch diameter. Belt is sufficiently tight if while one side remains straight the opposite side may be deflected inwardly 1/4 inch by light finger pressure. Secure the flange position by tightening the Set Screw. If the open screw hole lines up with a milled flat as a more favorable position, move the Set Screw to this hole. Make sure Screw seats on flat of milled groove. Do not tighten against thread on Pulley Core. Add Belt Guard (#36295 J) with two Fillister Head Screws (#25 S).

Refer to Page 25; assemble Lifter Lever (#36280 F) and the Link (#36280 G). Two holes are provided in the Lever (#36280 F). The hole closest to the Fulcrum Screw will provide more lift. Attach the Lifter Chain (#421 D-38) or Lifter Rod.

## MACHINE SPEED

The speed of the Machine is 4200 R. P. M., which may be modified, dependent upon the conditions of the operation. Since the Handwheel Pulley, which is grooved for a #1 or 3L section Vee Belt, has a pitch diameter of 2 1/4 inches, the size of the Motor Pulley may be approximated by the following formula:

$$\text{Pitch Dia. of Motor Pulley} = \frac{2.25 \times \text{R. P. M. of Machine}}{\text{R. P. M. of Motor}}$$

For Union Special Electro Drive Pulleys, add 1/4 inch to the calculated pitch diameter to obtain the outside diameter. Due to variations in actual pitch diameters, motor speeds, tension of the Jack Belt and size of variable pitch pulley, an absolute value will not be obtained and therefore, it becomes necessary to use a tachometer to determine the actual speed. The tachometer should be applied to the end of the MACHINE Shaft. It is unnecessary to remove the Belt Guard (#36295 J), since a hole has been provided for this purpose.

## SETTING UP THREAD STAND

Fasten Thread Stand to table board with three (#SC303) Flat Head Wood Screws (#12X1) at a location most convenient to bring into direct line the threads which lead into the Eyelets of Machine. See PL425 (packed with machine) for threading.

Brackets for attaching Thread Lead-in Guides should be located as shown on PL437 (also packed with machine) to prevent interference between Thread Cones and the Lead-in Guides.

## THREADING THE MACHINE

### PREFERRED THREADS

The Machine will operate satisfactorily with either left or right twist, although the direction of the Loper travel indicates right twist. A 70-3 or 80-3 cord is used in the needles and 30/2 to 50/2 soft mercerized yarn may be used in the Loper as well as the cover thread. The 25/1 to 28/1 yarns are definitely NOT recommended for the Loper since there is insufficient yarn to resist abrasion of wearing, although the seam has more than adequate strength.

It is more economical over a period of time to use the better grades of thread and yarn since they produce a more uniform stitch, thereby reducing the possibility of down-time. However, a selection of thread will depend on operation and material.

### SEQUENCE OF THREADING

Machine has been sewed off at factory and PL425 is packed with each machine as guide to threading and cone positioning. Sample of fabric should be closely observed as to introduction of fabric between toes of Presser Foot.

Place Cones on Thread Stand Seats and pull thread from cones on stand thru Lead-in Guides to Tension Post Eyelets as shown on PL425. Unwrap threads from Presser Bar, cut off and tie to threads from the Cones.

Turn Handwheel clockwise. Stop with Needle Bar at top of its stroke.

Pull threads from above needle eyes thru system until knots pass thru Needle Bar Head Eyelet. Cut off thread above knots and cut off close to Needle Eyes. DO NOT RE-THREAD NEEDLES AT THIS TIME.

With Needle Bar raised, lift Presser Foot and remove the factory sample. Observe method of entering Foot and the stitch formation.

Looper and Cover Thread can now be tied and pulled thru, with Needle Bar at highest point. It is unnecessary to re-thread the Looper and Cover Thread Carrier.

THREAD NEEDLES and place one ply of material under Foot. Manually turn clockwise several times and observe formation of stitch.

Check Tension Release when Foot is raised before sewing with power. When Foot is down, all threads have tension; when Foot is raised, all threads must be completely free. If these conditions are not met, refer to section on "Adjustment of Tension Release".

#### UNLOCKING THE STITCH

Turn the Handwheel in the operating or clockwise direction until the Needle Bar is in its lowest position, then, turn the Handwheel in the reverse direction until the Needle Bar has reached its highest position and moved downward approximately 1/8 inch to where the top of the Needle Lever Thread Eyelet is in line with the top of the mark on the Head Cover. Lift the Presser Foot as high as possible, thus opening the Tensions which allow the threads to be pulled from under the Foot freely.

With threads unlocked, it must be understood that it is only to introduce work under the Foot from behind the needles. Without a chain, material must be under the Foot when starting to sew.

If the stitch is unlocked and it is desired to start the machine without material, it is imperative to hold the free ends of all the threads firmly behind the Foot before starting the machine, until a small amount of chain is formed. This is termed "starting the chain". Machine will then chain indefinitely.

#### REPLACING THE NEEDLE

Union Special Needles for the FLATSEAMER are made with two flats on front of Shank. This design automatically assists operator in correctly locating the relative position of Needles in Needle Bar Head with respect to Looper. The Retainer, to the right of the fourth Needle, requires no orienting and consequently has no flat.

To remove Needle, bring Needle Bar to maximum height, break thread at eye, loosen Screw (#22738 H) and remove Needle. To replace Needle, make certain that Shank is inserted to full depth and that Screw is firmly seated on flat (Page 27).

## INSTRUCTIONS FOR SEWING ADJUSTMENTS

If the machine has been disassembled, re-adjusting for sewing-off is required, and it is suggested that the adjustments be made in the following sequence, which, through experience, has proven generally satisfactory. Familiarity with the machine will permit individual adjustments of an assembled machine to correct malfunction, but care should be taken to observe that the proper relationship of adjustment is maintained.

#### NEEDLE TO LOOPER SETTING

If the machine is assembled and it is desired to proceed with the Needle to Looper setting, the Upper Knife, Presser Foot, Throat Plate and Main Feed Dog should be removed.

To remove Presser Foot (#36220), raise Needle Bar to maximum height and remove Retainer (#36211), Upper Knife (#36270) and release knife pressure by unclamping Knife Guide (#36273 B). Remove Detachable Head Cover, left (#36289 A, Page 27) and Presser Foot Brace (#36278 E). Release Presser Bar Guide (#36278 B) and partially withdraw Presser Bar (#36278). Removal of Throat Plate and Main Feed Dog will permit observation of Needle to Looper setting.

## NEEDLES AND NEEDLE BAR

With Needle Bar motion at its highest travel, the fourth or lowest needle should be 17/32 inch from Throat Plate top. This adjustment may be obtained by using needle height Gauge (#21227 BU). To release the clamping of Needle Bar, loosen Screw (#22562 A, Page 23) in Needle Bar Connection (#51254 H), access to which is obtained by removal of Detachable Head Cover, left (#36289 A, Fig. A).

To position Needle Head square with the Throat Plate, insert the Needles into first and fourth positions only. The Upper Knife is used as a straight edge against the blades of the Needles and aligned with the cross grooves of the Throat Plate which has been previously secured by Throat Plate Screws (Fig. B).

Should removal of the Needle Bar become necessary, remove Head (#36218) by unscrewing and loosen the Binder Screw (#22562 A) in the Needle Bar Connection (#51254 J).

To replace the Needle Head, screw into Needle Bar and tighten to a torque of 17 lb. inches, or until Torque Bar (#21227 AR), inserted into cross hole in the Needle Bar, bends.

**CAUTION!** End of Needle Bar does not seat on top of Needle Bar Head. After tightening, check for expansion of Needle Bar by shoving Bar up into the Lower Bushing hole. If Bar has been expanded, it will bind in the Bushing. The Bar must be lapped to reduce bell shape. Normal assembly does not produce this bind.

Add second and third Needles, and Retainer.

### ALIGNMENT OF NEEDLES TO THROAT PLATE

Correct spacing of the Needles in Stitch Tongue is imperative to proper sewing conditions. Improper relation of Needles to the Stitch Tongue often results in mal-formed stitches (Fig. C).

In replacing a Stitch Tongue in the Throat Plate, care should be taken to assure the Stitch Tongue is not aligned improperly.

If the Stitch Tongue and Throat Plate are properly seated and the Needle position is not correct, it is probable that the Cylinder has been forced out of position. It is therefore necessary to realign the Cylinder as outlined on Page 12.

When the Needles are in correct position to the Throat Plate, the space at the left of the Needle in the slot of the Stitch Tongue is .006 inch more than the space at the right, as shown in Fig. C. Actually, the Needle Bar is centrally located with respect to the Throat Plate and Cylinder. However, to provide clearance on the left side of the Needle for the Needle Loops passing around the Loper during the down stroke of the Needles, the slots in the Stitch Tongue are made off center to the left. Accurate positioning of the Needles may be obtained by an adjustment of the Cylinder position.

Adjusting the Cylinder should be done with the Presser Foot and the Loper removed and with the Needles and Retainer certified for straightness. Remove from the top of Main Frame the Front Cover (#35887 AE, Page 21) and the Gasket. Loosen Cylinder Holding Screw (#22653 E-20, Page 35) at the front. Insert Screwdriver into the slot in Eccentric Stud (#36229 A-1), located to the left of screw. Position of the slot indicates position of the Eccentric, since center of Eccentric coincides with the center of the slot. Turning Stud clockwise moves the Cylinder to the left but in effect locates Needles to the right. Moving the Stud counterclockwise locates the Needles to the left. If machine has been in service for some time the Cylinder may not move freely by the rotation of the Eccentric, due to the joint seal compound setting. Light tapping with a wooden block at the joint or mid-point of the Arm may be necessary.

After alignment, tighten the Holding Screw and re-check position.

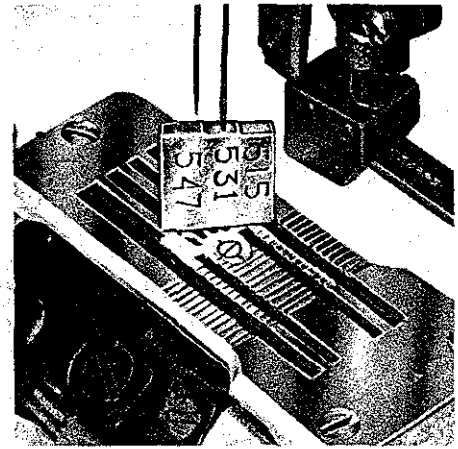

Fig. A

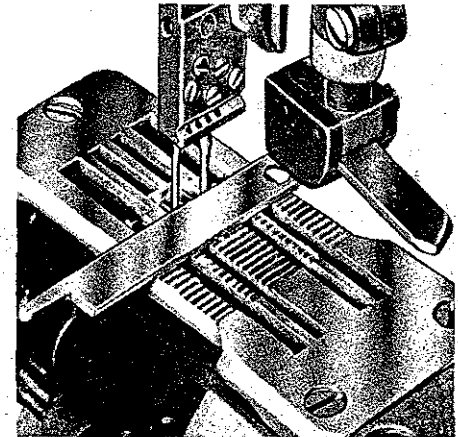

Fig. B

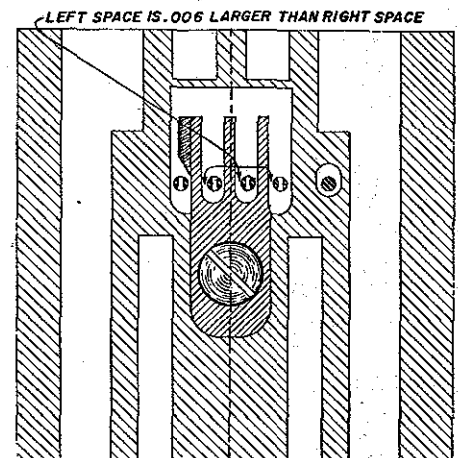

Fig. C

## USE OF LOOPER TRAVEL GAUGE

Remove Cylinder Hinged Spring Support Stud (#36283 C, Page 35) from Cylinder and attach Looper Travel Gauge Plate (#21227 CS) so that the bottom of gauge is approximately horizontal. Lock lightly in place with Screw (#22894 W). Remove left hand Screw (#604) used to hold Looper Needle Guard (#36210, Page 33) and attach Looper Travel Gauge Pointer (#21227 CM) using the same screw.

Turn Handwheel to set Looper (#36208 A) at the far right position. Set pointer at zero degrees by rotating Gauge Plate and then lock in place with Screw (#22894 W). Turn handwheel in clockwise direction to check the looper travel. If the Pointer stops on graduation mark which indicates 55° 40' or within graduation marks on either side, the looper travel is correct. If Pointer goes beyond either of the graduation marks mentioned above, it is necessary to alter the looper travel.

To adjust the looper travel, remove Front Top Cover (#35887 AE, Page 21) and the End Cover (#35887 Z). Loosen Locknut (#269, Page 33) and turn adjusting Screw (#22795 B) clockwise to decrease the looper travel and counterclockwise to increase looper travel.

NOTE: After setting looper travel, machine must be checked for synchronization.

### TIMING OF NEEDLES IN RELATION TO LOOPER

The movements of the Needles and Looper are timed with each other at the factory. If it has been necessary to disassemble the Main Shaft, the timing means must be checked.

Adjustment for timing the motion of the Needles to Looper is obtained in the Main Shaft Coupling (#35895 X, Page 23). This is constructed in two parts which are clamped together by Screws (#22519 F). Each end is oriented to its Shaft by Spot Screw (#22894 K) locating in Vee grooves milled in the Shafts. The Clamping Screws pass through slots which will allow a small amount of turning between the parts. This provides the necessary orienting for timing of the Main Shaft to the Crankshaft. After correct position is obtained by the factory, a timing mark is cut into the Coupling normal to the clamped faces and on the surface next to the Spot Screws. When the same Shafts and Coupling are used together, an accurate realignment of the mark will produce the same timing as before. However, it is never necessary in disassembling to release the Clamping Screws. Only for timing are the Clamping Screws released.

If one, or both, Shafts have been renewed, the timing will be altered within the manufacturing tolerances of the two Shafts, and therefore, the timing mark will not represent correct timing and retiming should be done as described below.

When the Needle Bar is at lowest position, the Looper has already started its advance toward the Needles, therefore, this position does not represent synchronization and Looper timing cannot be accomplished there. Synchronization occurs only when Needle Bar has risen .156 (5/32) inch. At this height, the Looper point should appear at the same relative position to the Needles whether rotation is effected clockwise or counterclockwise.

Synchronization is easily and accurately obtained by use of Gauge (#21227 CG, Page 43).

### INSTRUCTIONS FOR USING SYNCHRONIZING GAUGE NO. 21227 CG

- (1) Turn the Handwheel until Needle Bar (#35817 E, Page 27) is at bottom of its stroke.
- (2) Loosen the Presser Bar Regulating Screw (#36278 G, Page 25) and insert the Needle Bar Setting Block (#21227 CH, Fig. D, A) under the head of the Regularing Screw with the Stop Screw (#14087, Fig. D, B) above the Needle Bar. Clamp the Needle Bar Setting Block in this position.
- (3) Using the long portion of the Looper Clamp and Height Gauge (#21227 CJ, Fig. D, C) laid on its side as a gauge to set the Stop Screw (#14087) leave .156 (5/32) inch gap between the top of the Needle Bar at its lowest position and the head of the Stop Screw. Clamp Stop Screw in position using Nut (#1347 A, Fig. D, D).
- (4) Insert the Synchronizing Gauge Rod (#21227 CK, Fig. D, E) into the Looper Clamp and Height Gauge (#21227 CJ) securing it with Screw (#22738, Fig. D, F) and then clamp the gauge (#21227 CJ) to the heel of the Looper (#36208 A) with Screw (#22703 A, Fig. D, G).
- (5) Turn the Handwheel slowly in a clockwise direction until the Needle Bar strikes the Stop Screw. Then set the Synchronizing Gauge Rod so that the flattened end is about in the center of the graduations on the Needle Bar Setting Block (#21227 CH). This is accomplished by loosening Screw (#22738).
- (6) Turn the Handwheel in the opposite direction until the Needle Bar strikes the Stop Screw. The end of the Synchronizing Gauge Rod should come to the same graduation on the gauge. The difference must not exceed two marks of the graduation.
- (7) Follow this procedure two or three times to make certain the timing is perfect. If the above condition fails to be met, Coupling (#35895 X) must be repositioned. For access, remove Crank Chamber Cover (#35888 N) and Gasket (#35888 P, Page 21). Loosen the Coupling Clamping Screws (#22519 F). If the Synchronizing Gauge Rod moves more to the right while machine is rotated in a clockwise direction than in a counterclockwise direction, the Looper is too fast and the Main Shaft should be retarded. If the Synchronizing Gauge Rod moves more to the right while machine is rotated in a counterclockwise direction than a clockwise direction, the Looper is too slow and the Main Shaft should be advanced. The Coupling may be secured by one Screw while the gauging procedure is repeated to check the new relationship of the two Shafts.

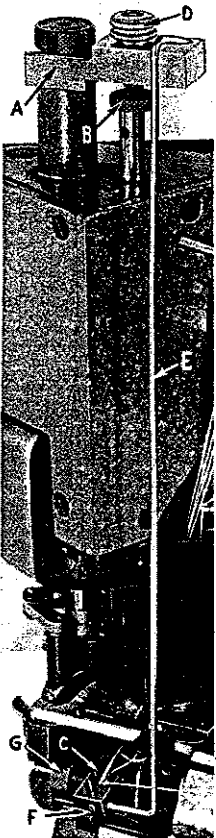

Fig. D

NOTE: If Stationary Knife (#36250) interferes with Synchronizing Gauge Rod (#21227 CK), remove Knife and proceed as described above.

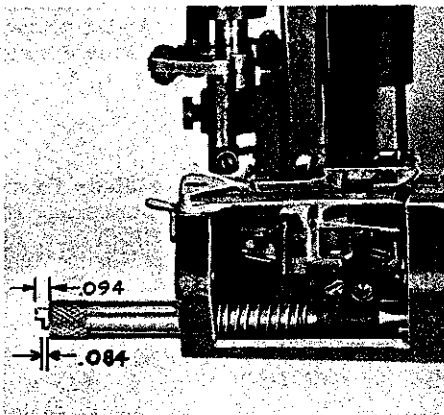

Fig. E

In the event Gauge (#21227 CG) is not available, synchronization may be checked as follows: Certify the Needle Bar height and Looper gauge. Insert #2 and #3 Needles into position. Using a Collar clamped on the upper portion of the Needle Bar, limit the downward stroke of the Needle Bar to stop within 5/32 inch of bottom of stroke. Observe carefully the position of the Looper point with respect to the Needles at both positions obtainable by clockwise and counterclockwise rotation of Handwheel. If machine is synchronized, both positions of the Looper will be exactly the same with regard to the Needles.

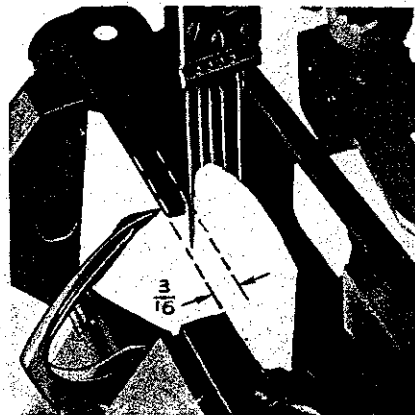

Fig. F

#### LOOPER ADJUSTMENT

With the throat plate and feed dogs removed, insert the looper (A, Fig. R) and tighten screw (B). It is important to align the looper blade 90° to the looper shaft. Place the narrow end of looper gauge (C), No. 21227 CU, in the middle feed bar slot of the cylinder casting (D). Insert a 1/8 inch diameter screw driver (E) in the half circle cutout of looper gauge and press the gauge against the right side of the feed bar slot and also against the looper blade. If the looper blade does not align with the end of the gauge, loosen screw (B) and turn looper (A) until blade of looper and gauge are aligned. Tighten screw (B) securely.

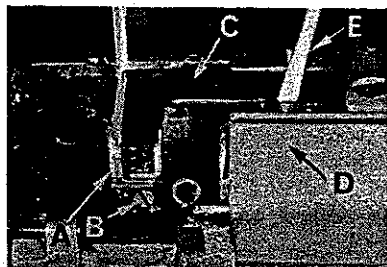

Fig. R

Set Looper Avoid to .094 inch, using gauge (#21227 BV, Fig. E). If gauge is not available, a depth micrometer may be used through the hole in the end of the Cylinder in line with the Looper Shaft, or a depth scale, if accurately read. Measurement is made of the extreme axial reciprocation of the Looper Shaft. In using the gauge (#21227 BV), first bring the Looper Shaft to its extreme motion toward the rear (away from operator), insert the gauge through the Looper Shaft hole in end of Cylinder until the Plunger is fully extended from the gauge while bearing firmly against end of Looper Shaft. Tighten Clamping Screw (#89, Page 35). Bring Looper Shaft to maximum forward position and check end of gauge for Plunger being flush with gauge body. The motion of the Plunger from extended position to flush represents .094 inch travel. If less looper avoid is required, use step on looper gauge, which is .084 inch (Fig. E). If conditions are not met, adjustment is obtained by removing Cylinder Side Cover (#36286, Page 35) and loosening Looper Avoid Link Ball Joint Stud, right (in #29478 DM, Page 31) to raise or lower Ball Joint. Raising Ball Joint shortens avoid motion and lowering lengthens avoid motion. Reposition gauge and repeat preceding method.

Normal Looper gauge is 3/16 inch. With the Looper motion at the extreme left of its travel, set Looper point to touch edge of gauge (#21225-3/16) while left Needle rests in Vee (Fig. F). Release Looper Holder Clamp Screw (#22652 A-6, Page 33) to move Looper Holder right or left. Before clamping the Screw tight, the axial setting of Looper point to back of Needle must be done. Turn Handwheel until Looper point is flush with right side of left Needle. Adjust Looper Holder with Screw on end of Looper Shaft to obtain a clearance between Needle and Looper point NOT to exceed .002 inch (Fig. G). Recheck Looper Gauge to be sure Holder has not slipped on Looper Shaft.

Looper Needle Guard may now be installed. Bring this Guard against first Needle (Fig. H). Pass Looper across all Needles and observe if free from pinching. Looper normally seats on top of the Holder. Clearance between top of the Looper and bottom of the Stitch Tongue should be .018 to .025 inch. Vertical adjustment is accomplished by means of a Screw set parallel to the Shank hole in the Looper Holder. Use a Feeler gauge with Needles removed to check the complete cycle.

#### FEED ADJUSTMENTS

##### FEED HEIGHT

Before assembling the Main Feed Dog and Differential Feed Dog, the Eccentric Stud (#36234 D, Page 29), which extends thru the Feed Bars at approximately the mid-area of the Cylinder, should be rotated until the slot

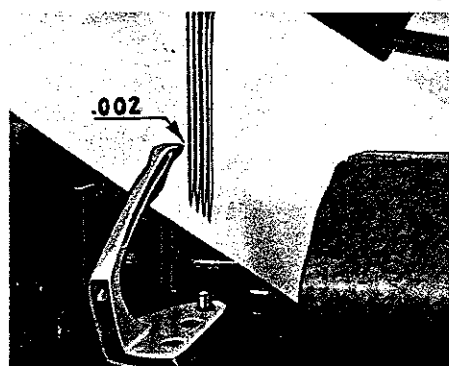

Fig. G

on the left end is set horizontally. This mid-setting allows for raising or lowering the two feeds simultaneously by turning the Eccentric. The total amount of adjustment obtainable is approximately 7/64 inch, measured at the rear of the Main Feed Dog. The Stud is locked to prevent rotation by Set Screw (#531, Page 35). (Fig. I, B)

Differential Feed may now be installed. Before assembling Main Feed Dog, add the Needle Guard to the Main Feed Dog and push the Guard to the end of its movement toward the rear. Tighten Screw.

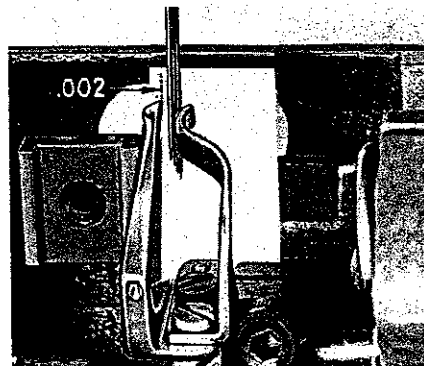

Fig. H

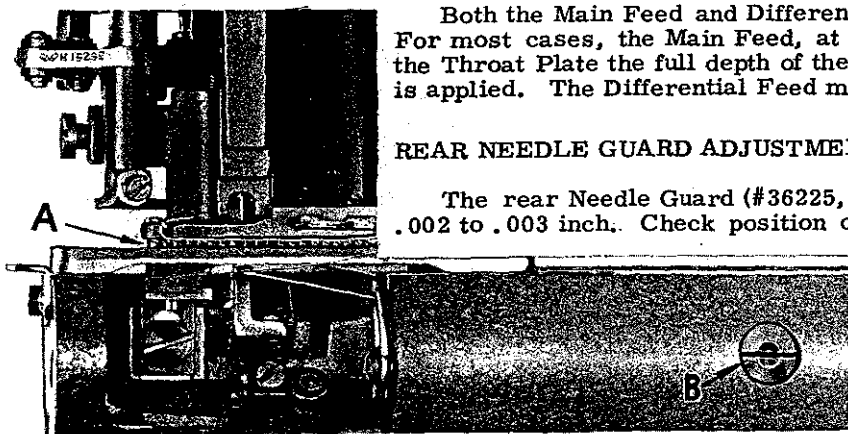

Fig. I

Both the Main Feed and Differential Feed may be individually adjusted to height. For most cases, the Main Feed, at its highest position, should rise above the top of the Throat Plate the full depth of the teeth when the normal Presser Spring pressure is applied. The Differential Feed may then be leveled to it (Fig. I, A).

#### REAR NEEDLE GUARD ADJUSTMENT

The rear Needle Guard (#36225, Page 29) should be set to clear first Needle by .002 to .003 inch. Check position on other Needles to avoid pinching. If the stitch length is altered by 1 stitch per inch, it will be necessary to re-check Needle Guard setting.

#### STITCH LENGTH

Adjustment for stitch length is made within the Arm of the Cylinder. Access is obtained by removal of Plug Screw (#22539 N) located on left side (see Page 35). A variation of stitch

length is obtained by loosening Screw (#36236 D) and sliding Clamp Block up or down (Page 31). If raised, the stitch length increases, and if lowered, decreases. Correct stitch length is obtained by trial on samples of material used. Screw must be tightened securely.

#### DIFFERENTIAL CONTROL

The amount of differential is controlled by the Lever at lower left of Cylinder (Page 35). If the Pointer is moved toward the operator, more differential or gathering occurs, and if moved toward the needles, reverse differential or stretching occurs. The Mounting Plate is numbered from 1 to 9, the differential action increasing with the numbers. Between 4 and 5, non-differential action is obtained.

Two Stop Screws (#36237 H, Page 35) are provided to limit the movement of the Lever to obtain predetermined position or to lock the Lever in one position. Intermediate positions between the Studs are maintained through friction of a Presser Spring upon the numbered plate. The pressure of the Spring may be controlled by means of the small Set Screw (#73 C, Page 35) in the indicator portion of the Lever.

#### PRESSER FOOT ADJUSTMENT

To assemble Presser Foot to machine, raise Needle Bar to its highest position and remove Retainer. While foot is slipped under Needles, swing the Upper Knife into opening and engage the Cover Thread Carrier and Hook Driving Segment (#36251 L, Page 37) with Hook Driving Sleeve (#36251 B, Page 33). The Presser Bar may now be passed thru the Segment and into the Presser Foot Shank. Tighten Presser Foot Screw (#94, Page 37). If right Presser Foot Brace has not been previously located, align Foot to Cylinder and secure with Presser Bar Guide (36278 J Page 33) and set right Brace (#36278 D, Fig. A) to contact Presser Foot. Otherwise, Foot may be swung against Brace first and Presser Bar Guide is then secured to Presser Bar.

Add left Presser Foot Brace (#36278 E). Check vertical freedom. Permit no play, yet no bind. Tighten Brace Screws when condition is satisfactorily met. Re-check for bind.

Link motion of Presser Foot should now be checked. Motion of Cover Thread Carrier Driving Lever and Shaft (#36251 G, Page 37) must jack-knife on approach to Needle Bar Head within 1/64 inch clearance as Handwheel is rotated clockwise (Fig. J). Meet this adjustment by loosening Screw in Hook Driving Sleeve Lever (#36251 C, Page 33), and rotating Sleeve (#36251 B).

Add Presser Spring (#36278 F) and Presser Spring Regulating Screw (#36278 G). Presser Bar Guide must not ride on Lifter Lever (#36280 J) when the feeding surface is below the Throat Plate. Allow 1/32 inch play between Lifter Lever and lift surface of Presser Bar Guide.

If Cover Thread Carrier and Cover Thread Hook are not in place, assemble Cover Thread Carrier first and position it so that a thread loop will be carried behind the first two Needles. Add Cover Thread Hook and set so that within one complete revolution the Hook comes within 1/64 to 1/32 inch of the Carrier at their closest position.

When the Hook swings to the left, it will pass over the Cover Thread if thread tension is maintained against the Hook movement. Therefore, the take-up should cast off after the Hook crosses the Cover Thread (Fig. K).

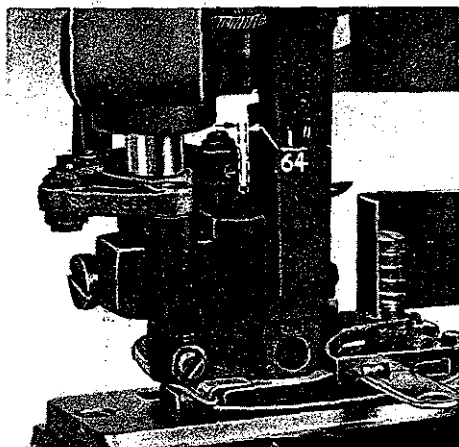

Fig. J

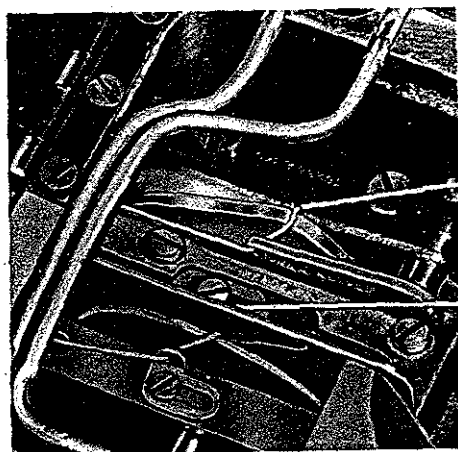

Fig. K



If difficulty is encountered, check the thread tension and Take-up timing and the condition of the point of the Hook proper. An extremely high polish and correct angle are necessary. Due to the clearance requirements, bending the Hook is not recommended.

Turn machine clockwise and observe transport of loop on Hook, which, as the third and fourth Needles descend, should not be pierced by any Needles nor picked by Retainer. These latter actions result in malformed stitches. If Hook and Carrier are too close together, the thread may be rolled off the Hook. Too much motion to the right will cause the Retainer to deflect from the Hook and strike the Throat Plate.

When the Needle Bar is at the top of its stroke, the Presser Foot Lift is approximately 5/16 inch and the Foot is not endangered by the Needle Head. However, when the Needle Bar is down, means have been provided to prevent raising the Foot into the path of the Needle Head and damaging the Cover Thread Hook. Adjustment is provided as follows:

Lower the Needle Bar by turning the Handwheel to the bottom of the stroke. Screw Presser Foot Lifter Stop Plunger (#36280 A, Page 25) clockwise until it strikes Crankshaft Counterweight. While applying pressure to raise the Foot, back Plunger out by unscrewing until Foot has risen and Cover Thread Hook is within 1/64 inch of underside of Needle Bar Head (Fig. L). Friction of threads in Stop Plunger Segment (#36280 C) will prevent Plunger from turning. Friction may be controlled by spreading opening of Segment.

The Frame Chip Guard (#36279, Page 27) is maintained in normal closed position by the cam action of its washer (#36279 A) against similar cam on Hub of the Chip Guard. These two surfaces have an obliquely milled step which imparts rotation through the axial pressure of Chip Guard Spring (#36279 B). Adjustment for position as well as tension is made when Guard is closed by slightly loosening Screw (#22277 B) and turning Washer (#36279 A) clockwise with Spanner Wrench (#21388 Y) until a slight separation of faces is obtained. Tighten Screw and test action. When Guard is closed, light resistance to opening should be felt.

#### ADJUSTMENT OF TRIMMING KNIVES

If the lower Knife (#36250, Page 37) has not been previously assembled, this must be done before upper Knife is inserted into Holder. Lower Knife should extend into slot between toes of Foot from 1/32 to 1/16 inch.

With Knife Holder Guide Collar (#36273 K, Page 33) in released condition, insert upper Knife into upper Knife Holder (#36273 G) and bring Knife Driving Bracket (#36273 M) to maximum left position. Set Blade so that its cutting edge clears Presser Foot by about 1/64 inch, then tighten Knife Holding Screw (#22894 X). Swing Knife to rear of opening in left of Foot and secure Guide to Shaft of Knife Holder Shank (#36273 A), allowing about 1/8 inch clearance between Guide and lower Bearing of Knife Driving Arm. To obtain the best trimming condition between Lower Knife (A, Fig. L 1) and Upper Knife (B, Fig. L 1), the distance between Knife Drive Connection Ball Joint, Left (#52848 B, Page 33) and Knife Drive Connection Ball Joint, Right (#52848 C, Page 33) should be set so that when the Upper Knife is at the left end of its travel, the sides of the Upper Knife and the sides of Lower Knife are parallel (Fig. L 1). A check should be made to insure that no interference is created between Knife Drive Bracket (#36273 M, Page 33) and left presser foot guide Screw (#22653 B-8, Page 27), when knife is at right end of travel and also between left toe of the Presser Foot and Knife Support (#36273 D, Page 33) when knife is at left end of travel. Repositioning of lower Knife may be necessary after trial seam is made in order to secure equal margin from the edges of the two plies to the two center rows of stitching.

#### NEEDLE THREAD ADJUSTMENTS

Four Needle Thread Take-ups (#36264 B) are provided for independent needle thread control (Fig. M, A). An approximate setting for the initial sew-off is to level the four Take-ups to the height of the thread in the Needle Lever Eyelet at its lowest position and then raise the first Take-up (nearest the operator) 1/8 inch and the second Take-up 1/16 inch. (The position and number of Take-ups corresponds respectively to those of the Needles.) Further adjustment may be necessary to effect a satisfactory Take-up of the Needle Thread Loops after cast-off from the Loper or to stretch the thread so that upon relaxation of the thread during the up-stroke, a satisfactory Needle Loop will be formed and skipping prevented. On the down stroke of the Needle, the first needle thread should be pulled up snugly against the Stitch Tongue to control the triangle of the subsequent stitch.

The four Frame Needle Thread Eyelets (#36271 A) should be set eye to eye, with the eyelets in the holder (#36271) as a starting point (Fig. M, B). The adjuster should change as necessary to control tension on the thread on the down stroke so that the needle thread loops around the Loper will remain firm and will not seek random positions.

The Unlocking Spring (#36271 E, Page 16, Fig. N, A) provides a proportional amount of pull-up of the needle threads when the machine is reversed for unlocking the stitch so that loops will not form on front of the Needles and become caught by the Loper. A minimum drop of the straight portion of the wire is desirable and is controlled by an Adjusting Screw (#22768 B). Usually 1/8 inch drop is sufficient. The tension of the Spring can be varied by turning the knurled knob of the Spring Holder (#36271 F) when released by loosening Screw (#22593). Adjust the tension so that 1/2 oz. upward pull will raise the straight portion of the Spring to be in line with the thread holes of the Knife Driving Bracket (#36273 M).

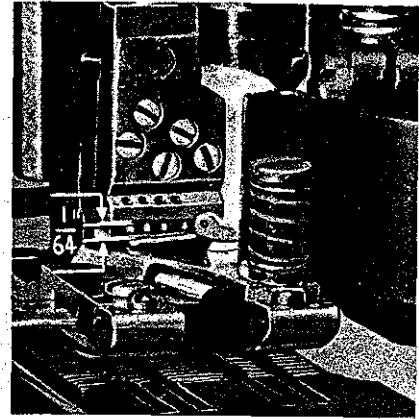

Fig. L

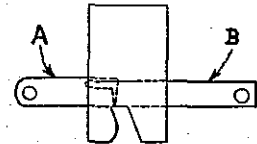

Fig. L 1

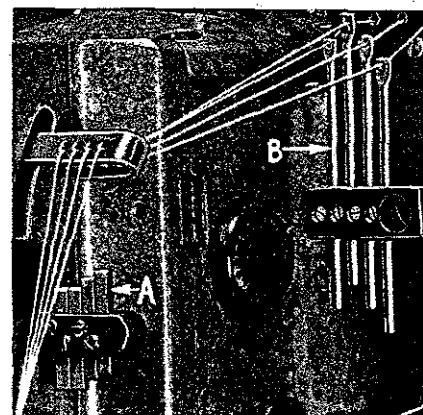

Fig. M

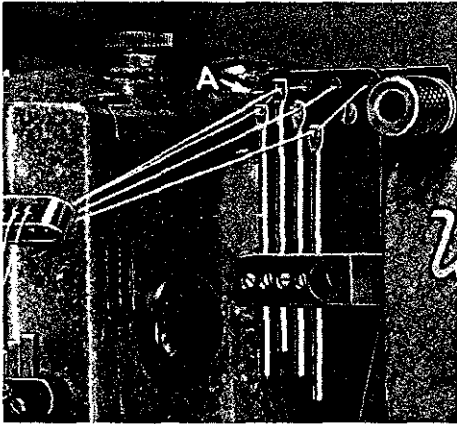

Fig. N

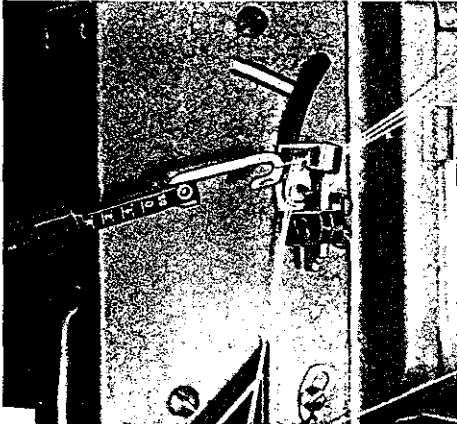

Fig. O

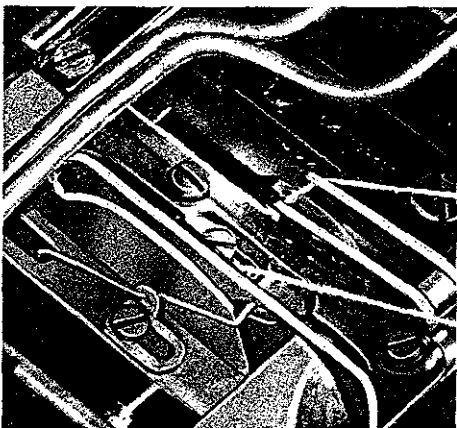

Fig. P

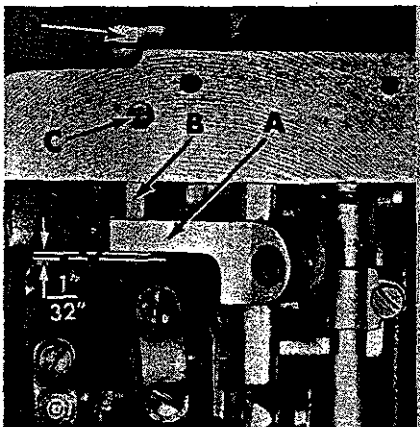

Fig. Q

Tension of the six threads is individually controlled. Tension of the four needle threads is seldom uniform as usually the first needle thread has more tension than the other three. As an average condition for sewing off, the Needle Thread Tensions may be set to the following #1, 3 1/2 oz., #2 3 oz., #3, 3 oz. and #4, 3 oz. Tension is measured by a horizontal pull through the Needle Lever Eyelet when the Needle Bar is almost at the bottom of stroke. A light Spring Scale such as a postal scale, similar to that illustrated (Fig. O) may be used. Further adjustment depending upon the material will produce a balanced stitch having the first and fourth needle loops pulled up and the second and third needle loops small and even. Only enough tension to pull up the stitch should be used.

#### LOOPER THREAD ADJUSTMENT

The Cast-off (#36204) is normally positioned with the right end flush with the Cast-off Support Plate (#36204 A, Fig. P). Moving the Cast-off Plate to another position will alter the Take-up timing and this method may be used to advantage where it is desired to change the timing very slightly without rotating the Take-up on the Main Shaft. The Thread Eyelets are placed to maximum right position. Moving these Eyelets to left will increase the amount of thread pulled off. Time the Take-up so that the casting-off from the sharp corner occurs when the Needle Bar has descended 7/64 inch from its highest position.

The tension of the Loper Thread, as measured by pulling straight from the end of Cylinder, is about 2 1/2 ozs., which is considerably more than flat bed machines making a similar stitch with one Loper. The actual tension selected after trial with the material and yarn used should be sufficient to prevent thread from being stolen from the Cone during the take-up portion of the cycle but the minimum depending on speed and condition of yarn or thread. An increase of tension above the normal amount might be desirable on some operations to pull the plies together more tightly. An excessive tension will have a tendency to disturb the triangle formation, especially while chaining.

#### COVER THREAD ADJUSTMENTS

Cover Thread Take-up Eyelet should be set with 3/32 inch gap between lower edge of Eyelet and Cast-off Plate (Fig. K). Position of this Eyelet determines the amount of thread pulled off for the cover stitch, thus controlling in conjunction with tension the fullness of the cover stitch loops. The Take-up should be timed to cast off during the interval between the crossing of the thread by the Cover Thread Hook and the start of rise of the Needle Bar. The Cast-off should always occur prior to Needle Bar rise. Otherwise, tension will remain in the Cover Thread and the formation of the first needle thread loop will be impaired.

The tension of the Cover Thread is approximately 1 oz., measured with a horizontal pull directly from the Eyelet which is located in the left wall of of the Main Frame. Only enough tension is used to effect thread control and prevent thread from being stolen from Cone. An increase in tension may be used to tighten Cover Thread, but abnormally high tension results in disturbance to the first row of stitching. Adjustment of the Cover Thread Carrier and the Cover Thread Hook of the Presser Foot is described under Presser Foot adjustment.

#### ADJUSTMENT OF TENSION RELEASE

When the Presser Foot is raised by the Foot Lifter Mechanism, the Thread Tensions are simultaneously released by means of a Tension Release Shaft (#36292 N, Detail 19, Page 25) which is rotated by Lever (#36280 M) lifting Tension Release Pins (#36292 L) lifting Tension Release Washers (#61292 H) which in turn releases pressure on the Tension Release Discs (#109). When Presser Foot is down, the Tension Discs clamp the thread and the tension is obtained. The Tension Release is set correctly when it begins to function as the Presser Foot is raised approximately 1/32 inch above the Throat Plate and is entirely released when the Presser Foot has reached its highest position. Positioning of the Tension Release Shaft may be adjusted by inserting a large screw driver into the right end of Shaft, loosening Screw (#22839 D) in Lever (#36280 M) permitting the Shaft to be turned clockwise to raise the Pins or counterclockwise to lower same.

NOTE: A 1/32 inch clearance should be maintained between Presser Bar Lifter Lever (#36280 J) and Presser Bar Guide (#36278 J). This can be accomplished by loosening screws in Lifter Lever Link Assembly (#36280 L) and shorten or lengthen Link as required.

#### HUNG FOOT ADJUSTMENT

Normally there should be 1/32 inch clearance between bottom of Presser Bar Guide (A, Fig. Q) and Presser Bar Guide Stud (B) with Presser Foot resting on Throat Plate (needle down position). Adjustment can be made by loosening Screw (C) and turning Nut (D) as required to attain specified setting. When sewing on extremely light weight material and/or feed cutting is a problem, the Presser Foot may be "HUNG" by raising Stud (B) until Guide (A) rests on shoulder of Stud, raising Presser Foot slightly, so that only the pressure of the Presser Foot Shoes contact material being sewn. Tighten Screw (C).



**INSTRUCTIONS FOR SEWING PLASTIC WITH NYLON THREAD  
AND WITHOUT THE 36211 RETAINER**

The machine should be adjusted as per the standard adjusting instructions, except for the following:

1. The Cast-off (#36204) is normally positioned with the right end flush with the Cast-off Support Plate (#36204 A). For sewing without the Retainer (#36211), move the Cast-off (#36204) to its extreme right position.
2. The Thread Eyelets on the Cast-off Support Plate (#36204 A) should be placed to the maximum right position.
3. Time the Take-up so that casting off from the sharp corner occurs when the Needle Bar has descended 9/64 inch from its highest position.
4. Place a Felt Pad on top of the machine under the needle threads against the back of the Stitch Unlocking Bracket (#36271 D). Saturate this felt with some thread lubricant such as Clearco. By doing this, the needle threads are lubricated and will pull up a better stitch on plastic.

**INSTRUCTIONS FOR INSTALLING OIL SEAL RING  
ON OIL PUMP SHAFT**

After the top covers have been removed, follow procedure as outlined below:

1. Remove Oil Pump Assembly from machine (Det. 1 thru 20, Page 23).
2. Remove both Housing Covers (#36297 A and 36297 F, Det. 1 and 13, Page 23).
3. Loosen Set Screws in Oil Pump Driven Gear (#35897 BR, Det. 11) and press Gear Shaft (#35897 BP, Det. 8) out of one Pump Gear (#51493 E, Det. 7).
4. Remove Oil Pump Driven Gear (#35897 BR).
5. If the inside surface of the Oil Pump Housing (#35897 BN, Det. 10) is rough or grooved, it is desirable to smooth this surface with a fine file. (This is the surface where the Steel Washer of the seal contacts the Pump Housing.)
6. To assemble, start from the left side and put the Pump Gear Shaft (#35897 BP) through the left side of the Pump Housing (#35897 BN). Next, put the Oil Pump Driven Gear (#35897 BR) on the shaft with the screw hub to the right. Then put Oil Seal Ring (#660-220, Det. 12A) next to the Gear. The Steel Washer (#6042 A, Det. 12B) goes between the Oil Seal Ring and the right side of the Pump Housing. (This is the surface mentioned in paragraph five that should be smooth on the Housing so that a good seal is obtained.) Place another Oil Pump Gear (#51493 E) on the right end of Gear Shaft (#35897 BP) and press on the Shaft until there is no end shake or bind.
7. Push the Oil Pump Driven Gear (#35897 BR) against the Oil Seal Ring and Washer so that it is snug. Then tighten Set Screws of Oil Pump Driven Gear. (CAUTION: Do not compress the Oil Seal Ring enough so that the Pump Shaft is hard to turn, as it will damage the Driving Gear (#35897 BY) on the Mainshaft. Torque should be set at 2 to 4 ounces inch.)
8. Replace the two Idle Gears (#51493 E) and put on the Housing Covers (#36297 A and 36297 F). Do not use any sealer between the Housing and Covers. Just be sure the surfaces are clean. After the Covers are tightened, it is desirable to put a bead of #1 Permatex along the joint of the Cover and the Housing.
9. When the Pump is replaced in the machine, care must be taken to be sure that the Cylinder Suction Tube enters the In-take Filter Screen and that the Gear on the Mainshaft is not too tight against the Gear on the Pump.

**INSTRUCTIONS FOR REPLACING GEAR SHAFT (36295 W)  
IN DRIVE UNIT (29480 CK)**

1. Remove Bottom Cover (#36295 Z, Det. 34, Page 19) and Pulley (#36295 G or 36295 H, depending on the Shaft being replaced).
2. Remove Oil Slinger Screws (#22882 A).
3. Remove Oil Wick (#666-128).
4. Remove Oil Tube (#36293 A). Insert a screwdriver into the Tube, tilt slightly, and lift the Tube out.
5. Remove Ball Bearing Cap (#36295 AC) from end of Housing and remove entire Shaft assembly.
6. Loosen Holding Screws (#36295 AE) on Collar of Ball Bearing (#660-302) and remove Ball Bearing from Shaft.
7. Loosen Holding Screw in Collar (#21705) and remove Collar and Bushing (#36295 Y).
8. Assemble the Bushing, Collar and Ball Bearing on the new Shaft and put the assembly into the Housing.
9. Replace the Oil Wick (#666-128) in the Oil Tube (#36293 A) and secure the Bushing (#36295 Y) in the Housing with the Oil Tube.
10. Replace the Ball Bearing Cap (#36295 AC).
11. Place a .009 inch thickness Gauge between the Gear Locating Pin (#36295 AB) and the Gear Shaft. Holding the Shaft against the Gauge and Pin, push the Ball Bearing Holder Collar away from center as far as possible and secure Holding Screws (#36295 AE). NOTE: To obtain access to Holding Screws (#95) secure Collar (#21705) with .001 inch oil clearance from Bushing (#36295 Y).
12. Replace Bottom Cover (#36295 Z) and Pulley (#36295 G or 36295 H) and fill with 3 ounces of oil.

**REMOVING EXCESSIVE PLAY FROM GEAR SHAFT**

To remove excessive end play in either Gear Shaft (#36295 W), remove Bottom Cover (#36295 Z). Loosen Holding Screws in Collar (#21705). Push the Gear Shaft toward the Pulley end as far as it will go and while holding the Shaft in this position, push the Collar against the Bushing (#36295 Y) and tighten Screws in Collar. Replace the Bottom Cover (#36295 Z).

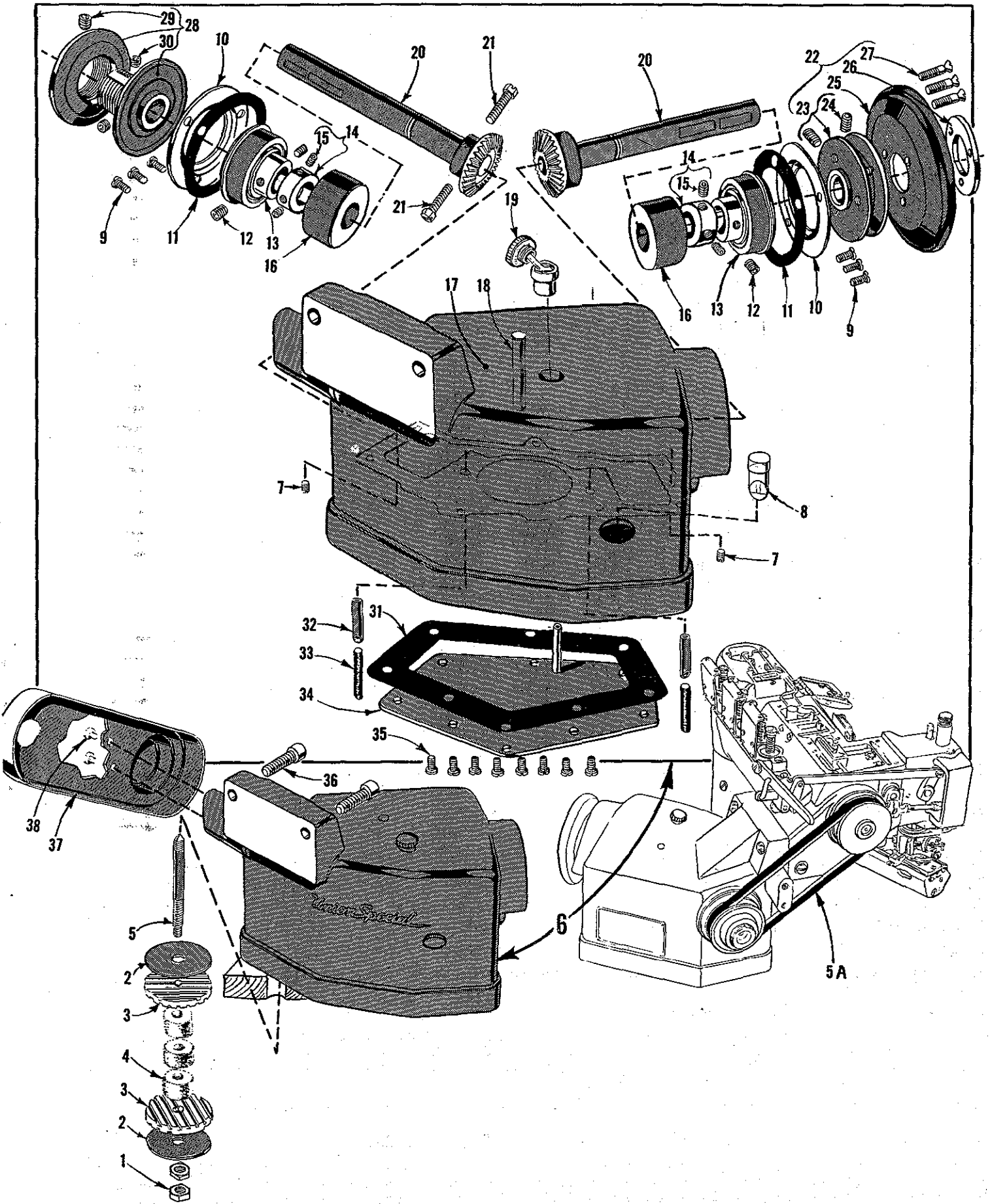

FOR STYLES 36200 A AND B ONLY

DRIVE UNIT, BELT GUARD AND MOUNTING STUD

<u>Ref. No.</u>	<u>Part No.</u>	<u>Description</u>	<u>Amt. Req.</u>
1	651 B-24	Nut -----	6
2	21371 UE	Washer -----	6
3	660-275	Neoprene Isolator -----	6
4	660-161	Felt Isolator -----	9
5	35895 R	Mounting Stud -----	3
5A	21261 M-210	Vee Belt, 21 inch outside circumference -----	1
6	29480 CK	Auxiliary Support and Drive -----	1
7	22571 A	Screw -----	2
8	51-120 Blk.	Oil Gauge -----	1
9	22569 C	Screw -----	6
10	36295 AC	Ball Bearing Cap -----	2
11	36295 AD	Gasket -----	2
12	36295 AE	Screw -----	4
13	660-302	Ball Bearing -----	2
14	21705	Collar -----	2
15	22894 C	Screw -----	2
16	36295 Y	Bushing -----	2
17	36295 V	Machine Support -----	1
18	36295 AB	Gear Locating Pin -----	1
19	666-96	Oil Filler Plug -----	1
20	36295 W	Gear Shaft -----	2
21	22882 A	Screw -----	2
22	36295 H	Handwheel Assembly -----	1
23	36295 F	Pulley -----	1
24	22894 V	Screw -----	2
25	61321 J	Handwheel -----	1
26	61321 L	Spacer Plate -----	1
27	22574	Screw -----	3
28	36295 G	Variable Speed Pulley -----	1
29	22650 AE-4	Socket Set Screw -----	1
30	22894 X	Screw -----	2
31	36295 AA	Gasket -----	1
32	36293 A	Oil Tube -----	2
33	666-128	Oil Wick -----	2
34	36295 Z	Bottom Cover -----	1
35	22569 C	Screw -----	8
36	22652 F-20	Screw -----	2
37	36295 J	Belt Guard -----	1
38	25 S	Screw -----	2

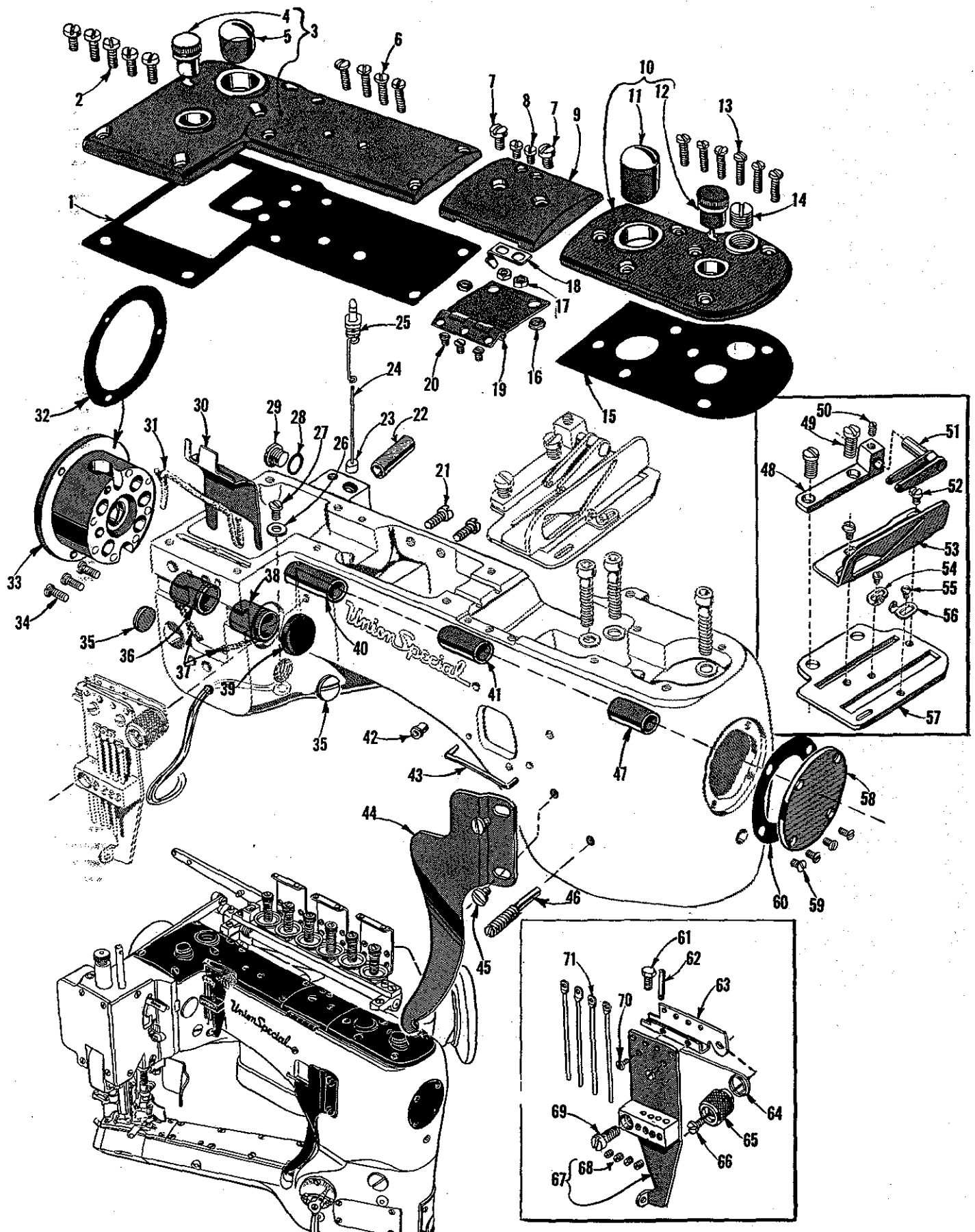

MAIN FRAME, OIL SIGHT GAUGE, MISCELLANEOUS COVERS, BUSHINGS AND TAKE-UP

Ref. No.	Part No.	Description	Amt. Req.
1	35888 P	Gasket-----	1
2	93	Screw-----	5
3	35888 N	Crank Chamber Cover-----	1
4	666-96	Oil Cup-----	1
5	50-537 Blk.	Oil Sight Gauge-----	1
6	22516 A	Screw-----	4
7	93 A	Screw-----	2
8	90	Screw-----	2
9	35887 X	Top Cover, middle-----	1
10	35887 AE	Top Cover, front-----	1
11	50-537 Blk.	Oil Sight Gauge-----	1
12	666-96	Oil Cup-----	1
13	22516 A	Screw-----	6
14	22539 M	Plug Screw-----	1
15	35887 AD	Gasket-----	1
16	12934 A	Nut-----	2
17	41071 G	Nut-----	2
18	35887 M	Spring-----	1
19	35887 R	Middle Cover Hinge-----	1
20	22564 B	Screw-----	3
21	93	Screw-----	2
22	36280 B	Presser Foot Lifter Stop Plunger Bushing-----	1
23	39593 C	Oil Gauge Float-----	1
24	36293 E	Oil Height Indicator-----	1
25	36293 B	Oil Sight Gauge-----	1
26	69 H	Washer-----	1
27	22711	Screw-----	1
28	41394 A	Gasket-----	1
29	22733 B	Oil Drain Screw-----	1
30	35889 H	Oil Shield-----	1
31	CL21	Oil Wick-----	1
32	56390 E	Bushing Housing Gasket-----	1
33	36290	Bushing Housing, including bushing-----	1
34	22569 B	Screw-----	3
35	22539 T	Plug Screw-----	2
36	36260	Needle Lever Shaft Bushing, rear-----	1
37	CL21	Oil Wick-----	2
38	35760 D	Needle Lever Shaft Bushing, front-----	1
39	35761 D	Bushing Cap-----	1
40	35890 E	Crankshaft Bushing, front-----	1
41	36290 A	Main Shaft Bushing, rear-----	1
42	62271 B	Thread Guide-----	1
43	35781 D	Looper Thread Guide Wire-----	1
44	36281	Looper Thread Shield-----	1
45	22829	Screw-----	1
46	22791 D	Screw-----	1
47	36290 B	Main Shaft Bushing, front-----	1
48	36256 A	Cover Thread Take-up Eyelet Holder-----	1
49	22839	Screw-----	2
50	73 C	Screw-----	1
51	36256	Cover Thread Take-up Eyelet-----	1
52	22 KH	Screw-----	2
53	36204	Cast-off-----	1
54	52958 F	Cast-off Plate Eyelet, rear-----	1
55	73 A	Screw-----	2
56	52958 C	Cast-off Plate Eyelet, front-----	1
57	36204 A	Cast-off Plate-----	1
58	35887 Z	End Cover-----	1
59	22564 B	Screw-----	4
60	35887 V	Gasket-----	1
61	22768 B	Screw-----	1
62	22799 B	Screw-----	1
63	36271 D	Stitch Unlocker Mounting Bracket-----	1
64	36271 E	Unlocking Spring-----	1
65	36271 F	Spring Holder-----	1
66	22593	Screw-----	1
67	36271	Needle Thread Eyelet-----	1
68	28 C	Screw-----	4
69	22596 D	Screw-----	1
70	73 A	Screw-----	2
71	36271 A	Frame Needle Thread Eyelet-----	4

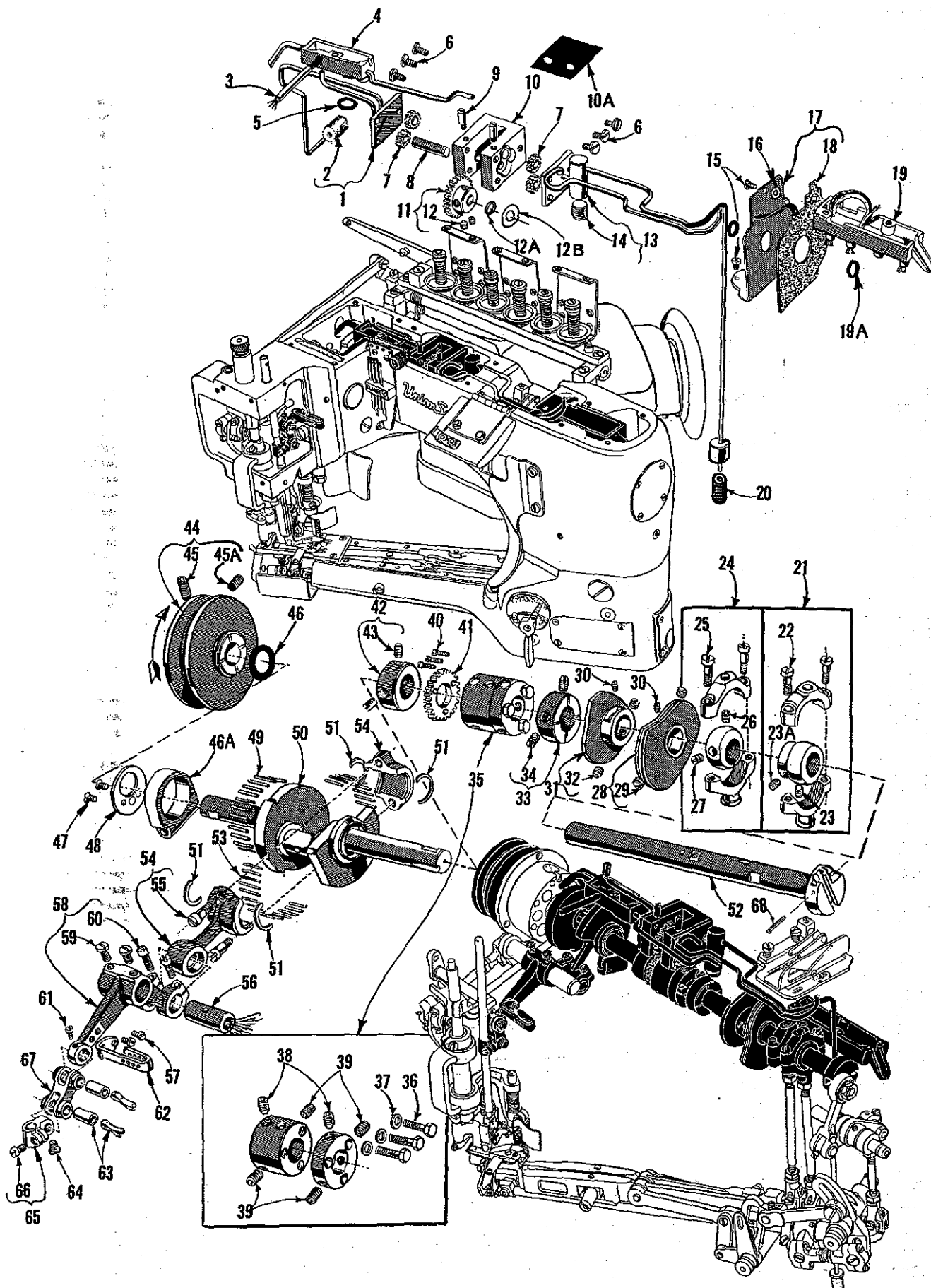

NEEDLE LEVER, MAIN SHAFT, CRANKSHAFT AND MISCELLANEOUS OILING

<u>Ref. No.</u>	<u>Part No.</u>	<u>Description</u>	<u>Amt. Req.</u>
1	36297 J	Housing Cover and Oil Tubes, rear	1
2	35897 BV	In-take Filter	1
3	35897 BU	Reservoir Outlet Tube	1
4	35894 J	Oil Reservoir, back	1
5	660-207	Oil Seal Ring	1
6	22585 A	Screw	6
7	51493 E	Gear	4
8	35897 BP	Gear Shaft	1
9	21756 G	Vent Screw	2
10	35897 BN	Oil Pump Housing	1
10A	35897 BW	Gasket	1
11	35897 BR	Oil Pump Driven Gear	1
12	89	Screw	2
12A	660-220	Oil Seal Ring	1
12B	6042 A	Washer	1
13	36297 A	Housing Cover and Oil Tubes, front	1
14	22571 B	Plug Screw	1
15	90	Screw	2
16	80265	Spacer Washer	1
17	36261 A	Take-up Shield Assembly	1
18	35861 D	Gasket	1
19	35894 L	Oil Reservoir, front	1
19A	660-202	Oil Seal Ring	2
20	36297 E	In-take Filter	1
21	29101 J	Feed Drive Eccentric Assembly	1
22	22587 E	Screw	2
23	22894 W	Set Screw	1
23A	22894 W	Set Screw	1
24	29103 T	Feed Lift Eccentric Assembly	1
25	22587 E	Screw	2
26	22894 W	Set Screw	1
27	22894 W	Set Screw	1
28	36223	Double Disc Take-up	1
29	22580	Screw	2
30	22801	Screw	2
31	36223 A	Cover Thread Take-up	1
32	22580	Screw	2
33	35895 L	Crankshaft Thrust Collar	1
34	531	Screw	2
35	35895 X	Main Shaft Coupling	1
36	22519 F	Screw	3
37	80265	Washer	3
38	22894 K	Spot Screw	2
39	22894 J	Set Screw	4
40	22797	Screw	3
41	35897 BY	Pump Driving Gear	1
42	35895 Y	Crankshaft Thrust Collar	1
43	531	Screw	2
44	36221 C	Pulley, for Styles 36200 AA, AB	1
	36221 B	Pulley, variable pitch, for Styles 36200 A, B	1
45	22894 H	Spot Screw, for No. 36221 C	1
45A	22894 E	Set Screw, for No. 36221 C	1
	22894 X	Screw, for No. 36221 B (.255-40 Thd.)	2
	22650 AE-4	Screw, for No. 36221 B (5/16-18 Thd.)	2
46	660-202	Oil Seal Ring	1
46A	36251 M	Eccentric Bearing	1
47	22766	Screw	2
48	36251 N	Needle Bearing Retaining Plate	1
49	36263	Needle Bearing Rollers	28
50	36222 A	Crankshaft	1
51	35763 G	Needle Bearing Retaining Ring	4
52	36222 C	Main Shaft	1
53	35763 F	Needle Bearing Rollers	28
54	35862	Needle Lever Connecting Rod	1
55	22587 B	Screw	2
56	35763	Needle Lever Connecting Rod Pin	1
57	77	Screw	2
58	35815 A	Needle Lever	1
59	22596 B	Screw	2
60	22729	Screw	2
61	77	Screw	1
62	36264 D	Needle Lever Thread Eyelet	1
63	51054	Link Pin	2
64	22564	Screw	1
65	51254 J	Needle Bar Connection	1
66	22562 A	Screw	1
67	56354 A	Needle Bar Link	1
68	660-219 P	Roll Pin	1

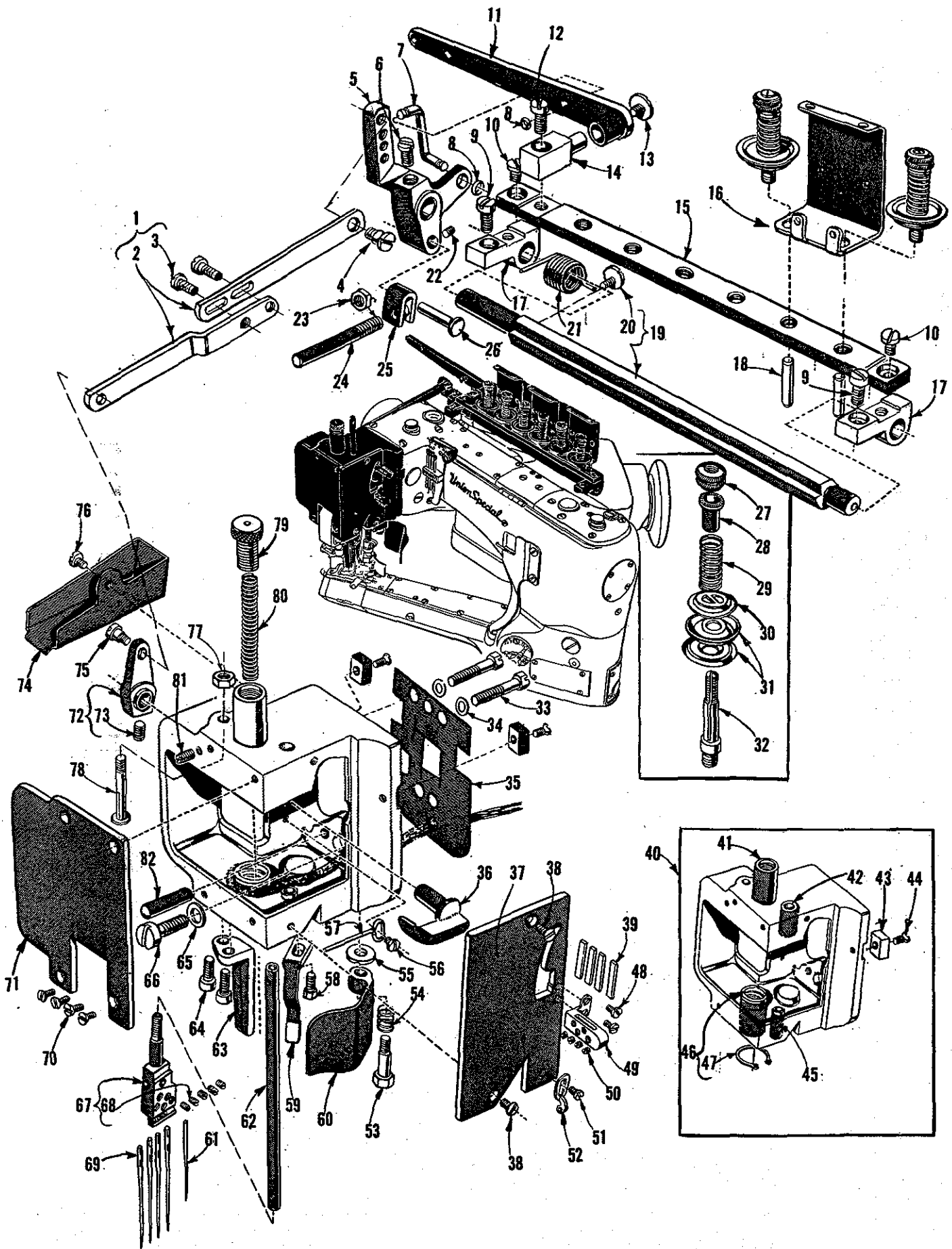



FOOT LIFTER AND TENSION PARTS

<u>Ref. No.</u>	<u>Part No.</u>	<u>Description</u>	<u>Amt. Req.</u>
1	36280 L	Lifter Lever Link Assembly - - - - -	1
2	36280 K	Lifter Lever Link - - - - -	1
3	22585 C	Screw - - - - -	2
4	86	Screw - - - - -	1
5	36280 M	Presser Bar Lifter Lever - - - - -	1
6	22839 D	Screw - - - - -	1
7	36280 G	Lifter Lever Connecting Link, for Styles 36200 A, B, X - - - - -	1
8	660-254 C	Retaining Ring, for Styles 36200 A, B, X - - - - -	2
9	22517	Screw - - - - -	2
10	94	Screw - - - - -	2
11	36280 F	Presser Foot Connection Lifter Lever, for Styles 36200 A, B, X - - - - -	1
12	22517	Screw, for Styles 36200 A, B, X - - - - -	1
13	255	Screw, for Styles 36200 A, B, X - - - - -	1
14	36280 N	Presser Foot Lifter Bearing Bracket, for Styles 36200 A, B, X - - - - -	1
15	36292-6	Tension Support - - - - -	1
16	36292 H	Tension Thread Eyelet - - - - -	3
17	36292 M	Tension Plate Bracket - - - - -	2
18	36292 L	Tension Disc Release Pin - - - - -	6
19	36292 N	Tension Release Shaft - - - - -	1
20	22784 F	Screw - - - - -	1
21	36292 K	Spring - - - - -	1
22	88 B	Screw - - - - -	1
23	258 A	Nut - - - - -	1
24	36280 A	Presser Foot Lifter Stop Plunger - - - - -	1
25	36280 C	Stop Plunger Segment - - - - -	1
26	36280 D	Stop Plunger Segment Pin - - - - -	1
27	108	Tension Nut - - - - -	6
28	107	Tension Post Ferrule - - - - -	6
29	51292 F-2	Tension Spring, cover thread - - - - -	1
	51292 F-4	Tension Spring, looper thread - - - - -	1
	51292 F-5	Tension Spring, needle thread - - - - -	4
30	61292 H	Tension Release Washer - - - - -	6
31	109	Tension Disc - - - - -	12
32	36292 J	Tension Post - - - - -	6
33	22759 A	Screw - - - - -	2
34	6042 A	Washer - - - - -	2
35	36289 B	Baffle Plate - - - - -	1
36	36280 J	Presser Bar Lifter Lever - - - - -	1
37	36289	Head Cover, front - - - - -	1
38	22524	Screw - - - - -	2
39	36264 B	Needle Thread Strike-off Pin - - - - -	4
40	36229 B	Detachable Sewing Head - - - - -	1
41	36278 A	Presser Bar Bushing - - - - -	1
42 to 82		See following page	

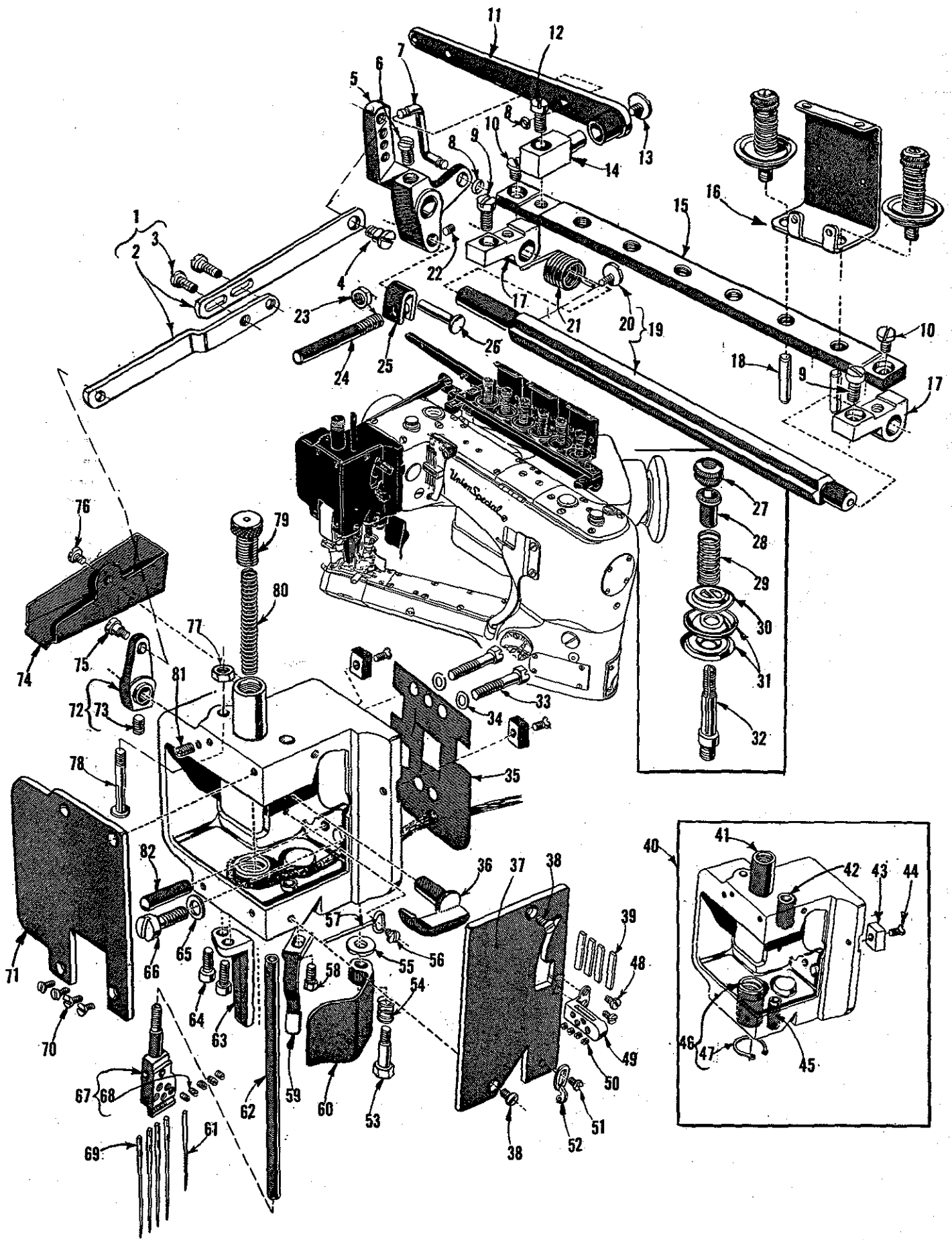

DETACHABLE HEAD, COVERS, NEEDLE BAR, NEEDLE BAR HEAD

<u>Ref. No.</u>	<u>Part No.</u>	<u>Description</u>	<u>Amt. Req.</u>
1 to 41		See preceding page	
42	35859 D	Needle Bar Bushing, upper - - - - -	1
43	35767	Sewing Head Key - - - - -	2
44	22524	Screw - - - - -	2
45	35859 C	Needle Bar Bushing, lower - - - - -	1
46	36251 D	Cover Thread Carrier and Hook	
		Driving Sleeve Bushing - - - - -	1
47	660-261	Retaining Ring - - - - -	1
48	28	Screw - - - - -	2
49	36264 A	Needle Thread Take-up - - - - -	1
50	28 A	Screw - - - - -	4
51	28	Screw - - - - -	1
52	51259	Cover Thread Eyelet - - - - -	1
53	22777 B	Screw - - - - -	1
54	36279 B	Spring - - - - -	1
55	36279 A	Washer - - - - -	1
56	22513	Screw - - - - -	1
57	36294 C	Oil Deflector - - - - -	1
58	22881 A	Screw - - - - -	1
59	36278 D	Presser Foot Guide, right - - - - -	1
60	36279	Frame Chip Guard, for Styles 36200 A, B, AA, AB - - - - -	1
-	36279 G	Frame Chip Guard, for Style 36200 AK -	1
-	36279 E	Frame Chip Guard, for Styles 36200 X, AX - - - - -	1
61	36211-029	Retainer marked, "029", furnished with machine - - - - -	1
	36211-027	Retainer marked, "027", available as extra send and charge - - - - -	1
	36211-025	Retainer, marked "025", available as extra send and charge - - - - -	1
62	35817 E	Needle Bar, marked "DY" - - - - -	1
63	36278 E	Presser Foot Guide, left - - - - -	1
64	22653 B-8	Screw - - - - -	2
65	6042 A	Washer - - - - -	1
66	318	Screw - - - - -	1
67	36218	Needle Bar Head - - - - -	1
68	22738 H	Screw - - - - -	5
69	118 GKS-075/029	Needle, for Styles 36200 A,B, AA, AB, AK - - - - -	4
-	118 GKS-080/032	Needle, for Styles 36200 X, AX - - - - -	4
70	22524	Screw - - - - -	4
71	36289 A	Detachable Head Cover, left - - - - -	1
72	35880 M	Lifter Lever Link Connection - - - - -	1
73	22894 J	Screw - - - - -	1
74	36294 B	Oil Guard - - - - -	1
75	86	Screw - - - - -	1
76	22585 C	Screw - - - - -	1
77	12538	Nut - - - - -	1
78	36278 H	Presser Bar Guide Stud - - - - -	1
79	36278 G	Presser Bar Regulating Screw - - - - -	1
80	36278 F	Spring - - - - -	1
81	22560 A	Screw - - - - -	1
82	664 F-16	Taper Pin - - - - -	1

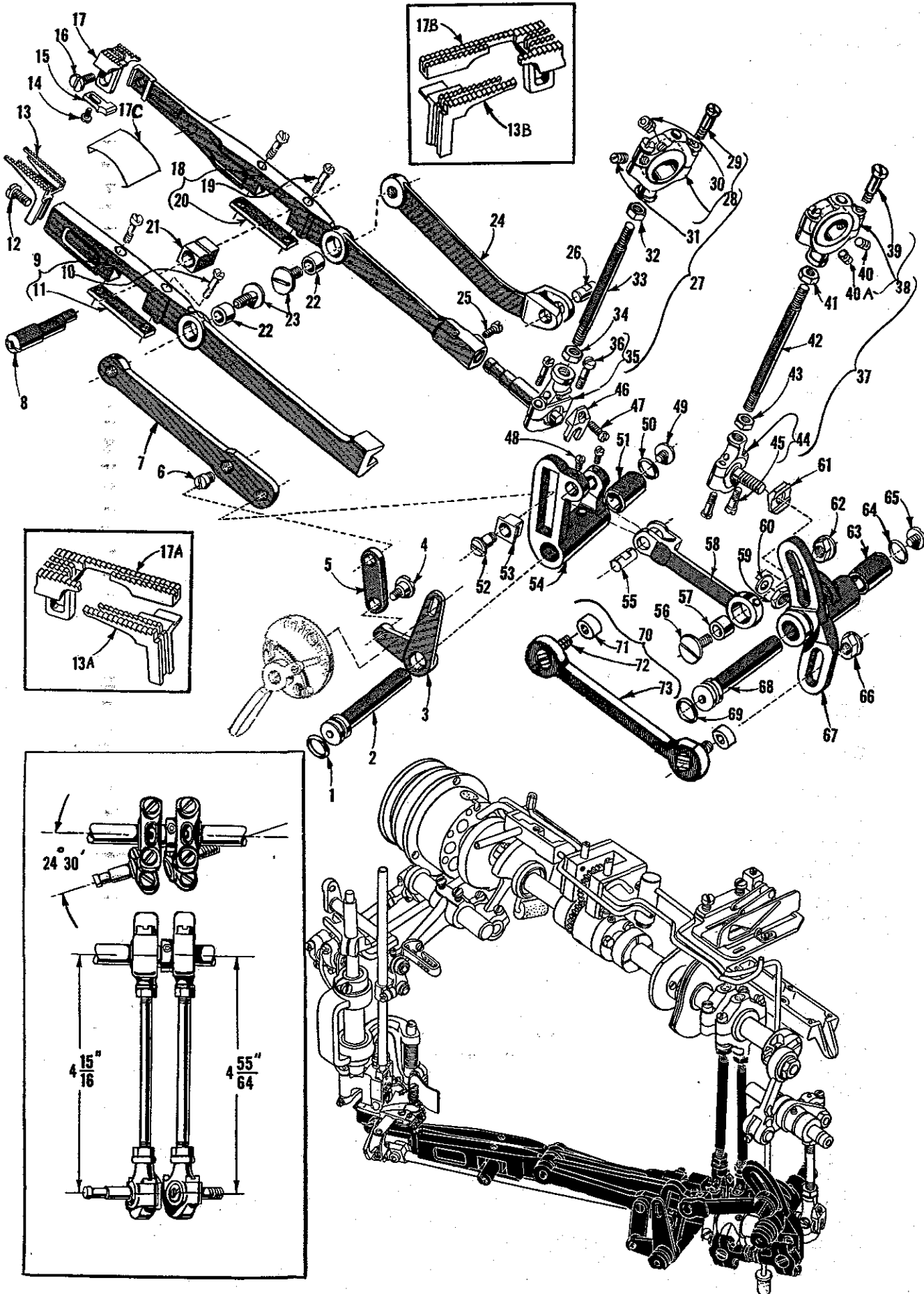

DIFFERENTIAL FEED BAR, MAIN FEED BAR, FEED LIFT  
ECCENTRIC ASSEMBLY

Ref. No.	Part No.	Description	Amt. Req.
1	660-207	Oil Seal Ring -----	1
2	36236 A	Feed Rocker Shaft -----	1
3	36237	Differential Feed Adjusting Lever -----	1
4	22504 C	Screw -----	1
5	36237 A	Differential Feed Adjusting Link -----	1
6	22845 M	Screw -----	1
7	36236 F	Differential Feed Bar Driving Link -----	1
8	36234 D	Feed Bar Eccentric Stud -----	1
9	36234 F	Differential Feed Bar -----	1
10	22587 H	Screw -----	2
11	36234 G	Feed Bar Plate -----	1
12	22528	Screw -----	1
13	36226 A	Differential Feed Dog, marked "FV", 14 teeth per inch, for medium to heavy operations -----	1
	*36226 B	Differential Feed Dog, marked "PB", 16 teeth per inch, for light operations -----	1
13A	*36226 C	Differential Feed Dog, marked "PF", 14 teeth per inch, left hand offset -----	1
13B	*36226 D	Differential Feed Dog, marked "FN", 14 teeth per inch, right hand offset -----	1
14	87 U	Screw -----	1
15	36225	Needle Guard, marked "FZ" -----	1
16	22528	Screw -----	1
17	36205 A	Main Feed Dog, marked "PK", 14 teeth per inch, for medium to heavy operations -----	1
	*36205 B	Main Feed Dog, marked "PL", 16 teeth per inch, for light operations -----	1
17A	*36205 C	Main Feed Dog, marked "PM", 14 teeth per inch, for use with No. 36226 C differential feed dog -----	1
17B	*36205 D	Main Feed Dog, marked "FP", 14 teeth per inch, for use with No. 36205 D differential feed dog -----	1
17C	35884 K	Lower Lint Shield -----	1
18	36234 E	Main Feed Bar -----	1
19	22587 H	Screw -----	2
20	36234 G	Feed Bar Plate -----	1
21	36234 C	Feed Bar Slide Block -----	1
22	36236 H	Bushing -----	2
23	36236 G	Driving Link Stud -----	2
24	36236 E	Main Feed Bar Driving Link -----	1
25	33174 B	Screw -----	1
26	62238 A	Link Pin -----	1
27	29478 CS	Feed Lift Eccentric Assembly -----	1
28	29103 T	Feed Lift Eccentric Assembly Ball Joint -----	1
29	22587 E	Screw -----	2
30	22894 W	Set Screw -----	1
31	22894 W	Set Screw -----	1
32	269	Nut, left thread -----	1
33	36244	Connecting Rod -----	1
34	18	Nut, right thread -----	1
35	36244 A	Ball Joint, complete -----	1
36	97 A	Screw -----	2
37 to 75		See following page	

\* Available as an extra send and charge item.

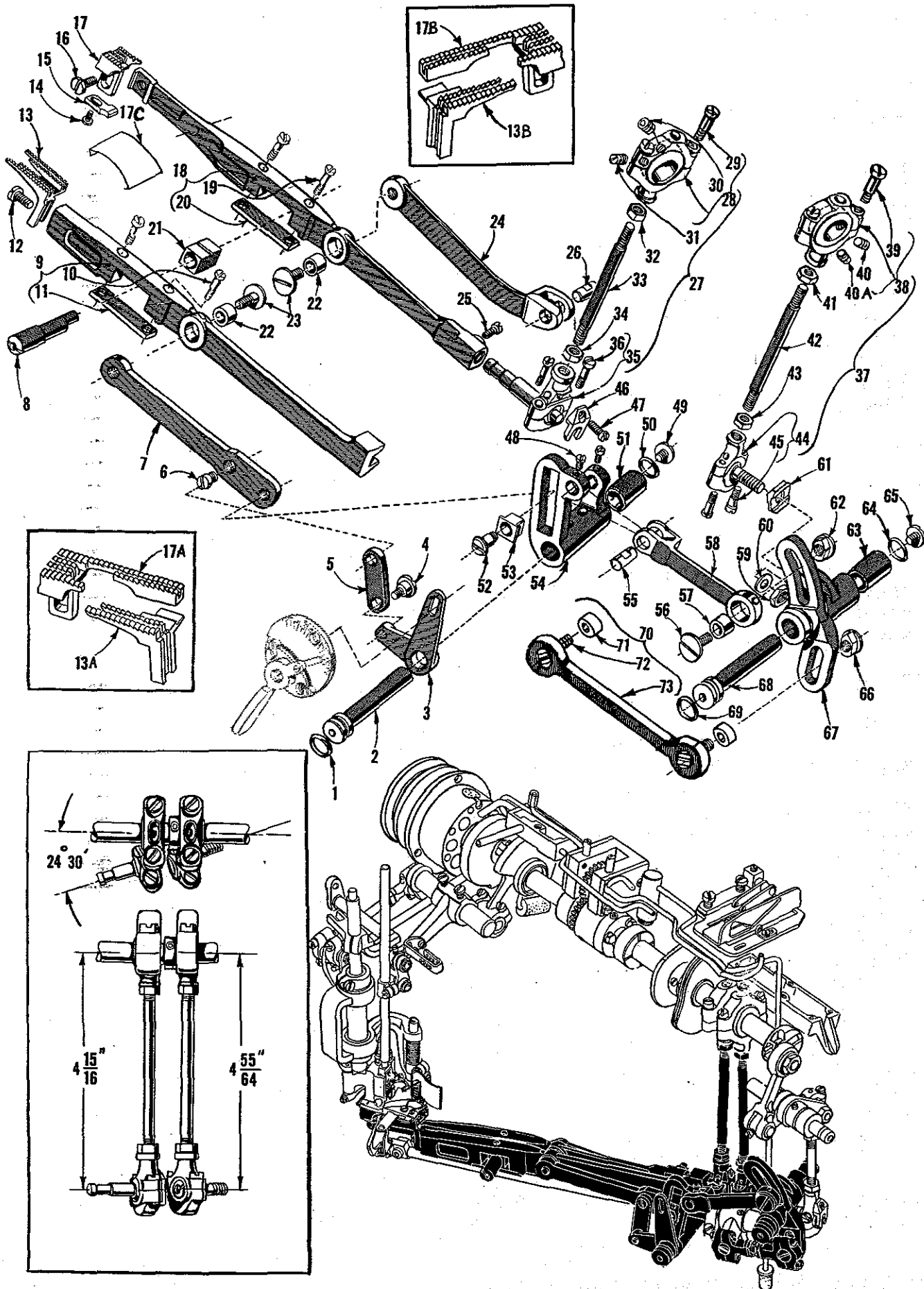

FEED DRIVE ASSEMBLY, FEED ROCKER, LOOPER AVOID  
LINK BALL JOINTS

Ref. No.	Part No.	Description	Amt. Req.
1 to 36		See preceding page	
37	29478 CT	Feed Drive Assembly-----	1
38	29101 J	Feed Drive Eccentric Assembly-----	1
39	22587 E	Screw-----	2
40	22894 W	Set Screw-----	1
40A	22894 W	Set Screw-----	1
41	269	Nut, left thread-----	1
42	43246	Connecting Rod-----	1
43	18	Nut, right thread-----	1
44	35846	Ball Joint-----	1
45	22729 C	Screw-----	2
46	41255 B	Ball Fork-----	1
47	22747	Screw-----	1
48	77	Screw-----	2
49	22711	Screw-----	1
50	660-206	Oil Seal Ring-----	1
51	36236 B	Bushing-----	1
52	36236 J	Differential Driving Link Stud-----	1
53	36236 K	Differential Feed Driving Link Slide Block-----	1
54	36236	Feed Rocker-----	1
55	62238 A	Link Pin-----	1
56	36236 D	Driving Link Screw-----	1
57	36236 H	Bushing-----	1
58	36236 C	Feed Rocker Driving Link-----	1
59	258	Nut-----	1
60	6042 A	Washer-----	1
61	35846 B	Washer-----	1
62	35766 B	Nut-----	1
63	36236 B	Bushing-----	1
64	660-206	Oil Seal Ring-----	1
65	22711	Screw-----	1
66	35766 B	Nut-----	1
67	35842 J	Feed Drive and Looper Avoid Drive Lever-----	1
68	36236 A	Feed Drive Shaft-----	1
69	660-207	Oil Seal Ring-----	1
70	29478 DM	Looper Drive Shaft Cross Head Connecting Rod Assembly-----	1
71	56341 F	Ferrule-----	2
72	35851 K	Screw-----	2
73	35851 M	Connecting Rod-----	1

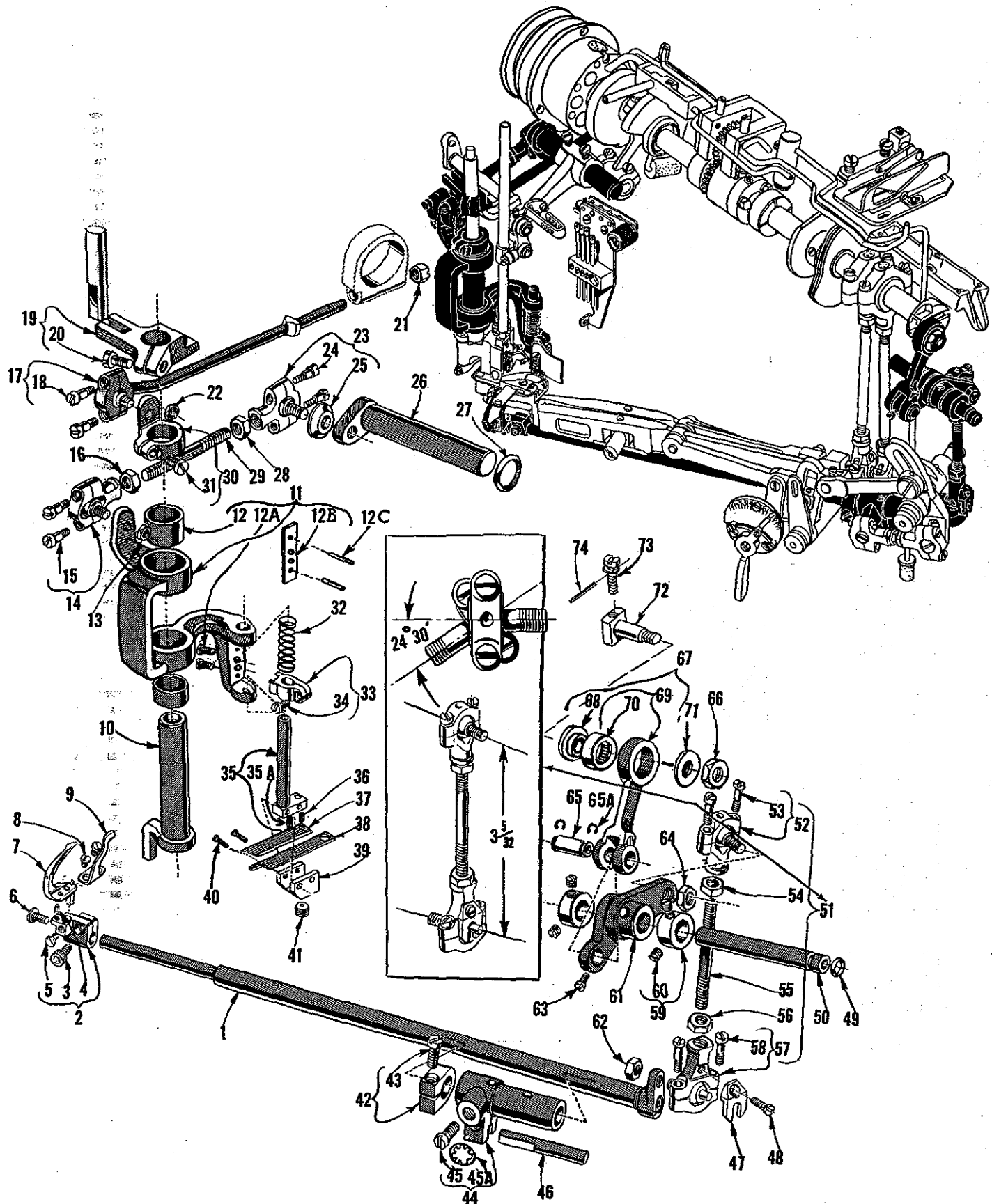



LOOPER ROCK SHAFT, LOOPER DRIVE AND KNIFE DRIVE PARTS

Ref. No.	Part No.	Description	Amt. Req.
1	36249	Looper Rocker Shaft	1
2	36248	Looper Holder	1
3	22652 A-6	Screw	1
4	1096 B	Looper Adjusting Screw	1
5	22564 D	Screw	1
6	22585 A	Screw	1
7	36208 A	Looper	1
8	604	Screw	2
9	36210	Looper Guard	1
10	36251 B	Cover Thread Carrier and Hook Driving Sleeve	1
11	36273 M	Knife Driving Bracket	1
12	36273 F	Bushing	2
12A	605 A	Screw	2
12B	36273 J	Knife Holder Guide Plate	1
12C	660-219 D	Roll Pin	2
13	12934 A	Nut	1
14	52848 B	Knife Drive Connection Ball Joint, left	1
15	22729 C	Screw	2
16	18	Nut	1
17	36251 P	Cover Thread Carrier and Hook Driving Connecting Rod Ball Joint	1
18	97 A	Screw	2
19	36278 J	Presser Bar Guide	1
20	22585	Screw	1
21	52841 H	Nut	1
22	12934 A	Nut	1
23	52848 C	Knife Drive Connection Ball Joint, right	1
24	22729 C	Screw	2
25	36 G	Washer	1
26	36261	Knife Drive Lever	1
27	660-202	Oil Seal Ring	1
28	269	Nut	1
29	4761	Knife Drive Connecting Rod	1
30	36251 C	Sleeve Driving Lever	1
31	22585	Screw	1
32	36273 C	Knife Holder Spring	1
33	36278 J	Knife Holder Guide Collar	1
34	22562 A	Screw	1
35	36273 A	Knife Holder Shank	1
35A	1096 B	Screw	1
36	22799 N	Screw	1
37	36273 D	Knife Support	1
38	36270	Knife, upper	1
39	36273 G	Knife Holder	1
40	22767 A	Screw	2
41	22894 X	Screw	1
42	35751 G	Looper Shaft Collar	1
43	22572 B	Screw	1
44	36249 B	Looper Shaft Sleeve	1
45	22729 D	Screw	1
45A	652 C-9	Washer	1
46	36278 C	Stud	1
47	41255 B	Ball Fork	1
48	22747	Screw	1
49	660-221	Oil Seal Ring	1
50	36253 B	Looper Drive Lever Shaft	1
51	29478 CU	Looper Drive Connecting Rod Assembly	1
52	35851 L	Ball Joint, Upper	1
53	22729 C	Screw	2
54	269	Nut	1
55	4761	Connecting Rod	1
56	18	Nut	1
57	39145 A	Ball Joint, lower	1
58	97 A	Screw	2
59	12865	Collar	2
60	88	Screw	1
61	36253 A	Looper Drive Lever	1
62	258 A	Nut	1
63	77	Screw	1
64	15037 A	Nut	1
65	52336	Link Pin	1
65A	660-215	Retaining Ring	2
66	269	Nut	1
67	29478 DR	Looper Drive Connecting Rod and Ferrule Sub-Assembly	1
68	36253 J	Ferrule	1
69	36253 H	Looper Drive Connecting Rod, upper	1
70	660-311	Needle Bearing	1
71	20	Washer	1
72	36253 G	Looper Drive Crank Stud	1
73	22795 B	Screw	1
74	660-219 P	Roll Pin, for main shaft	1

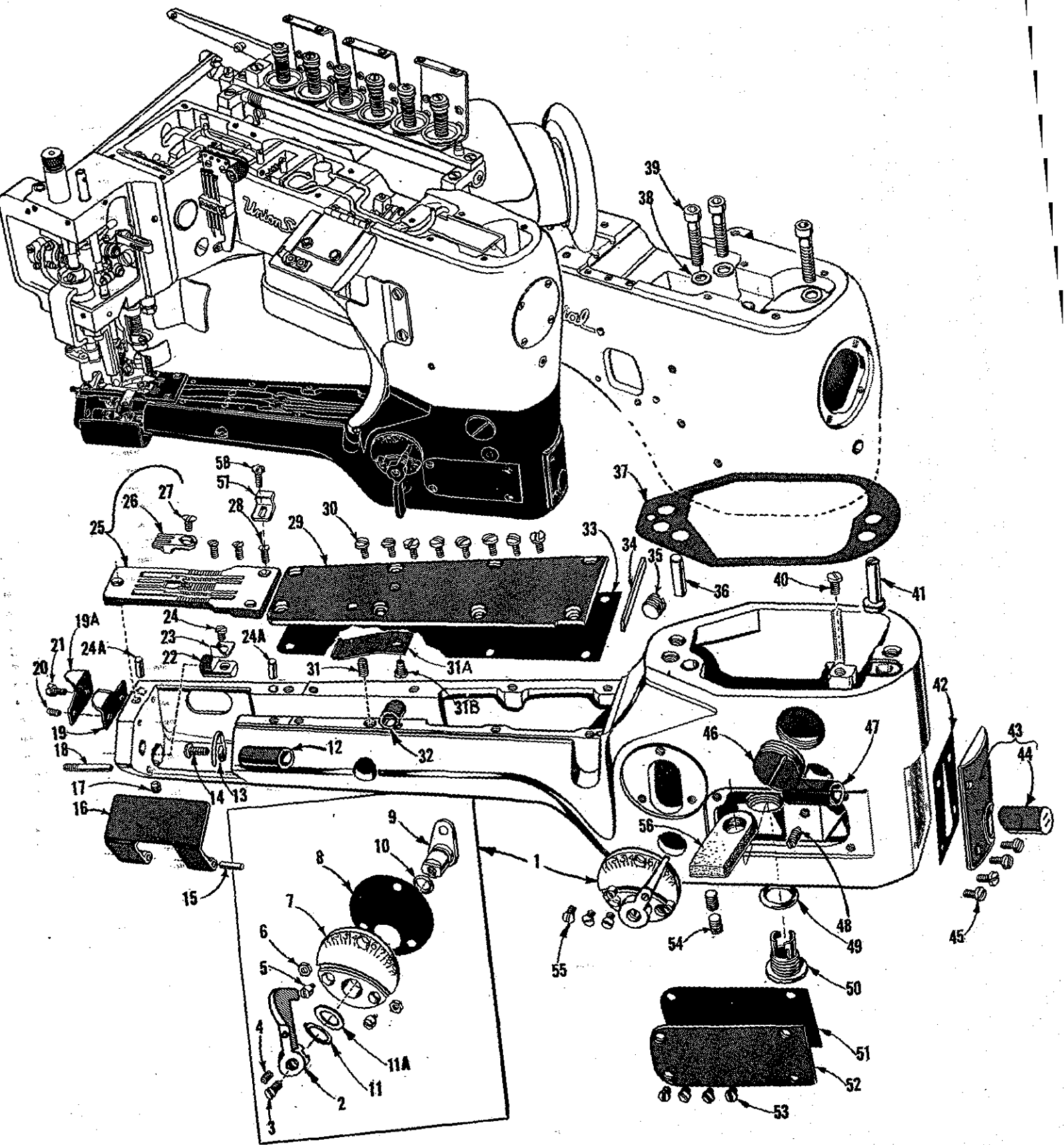

DIFFERENTIAL FEED CONTROL, CYLINDER COVERS AND BUSHINGS

<u>Ref. No.</u>	<u>Part No.</u>	<u>Description</u>	<u>Amt. Req.</u>
1	29478 CZ	Differential Feed Control Assembly-----	1
2	36237 G	Operating Lever -----	1
3	538	Screw-----	1
4	73 C	Screw-----	1
5	36237 H	Stop Screw -----	2
6	60078 Z	Nut-----	2
7	36238	Adjusting Plate -----	1
8	36238 E	Gasket-----	1
9	36237 E	Adjusting Lever-----	1
10	660-220	Oil Seal Ring -----	1
11	36237 J	Spring Washer-----	1
11A	652 K-24	Fiber Washer -----	1
12	35850 D	Looper Shaft Bushing, rear -----	1
13	36256 B	Looper Thread Guide Wire -----	1
14	22849	Screw-----	1
15	35883 G	Pin-----	1
16	36283 A	Cylinder Hinged Cover -----	1
17	22894 W	Screw -----	1
18	22791 E	Screw Pin -----	1
19	36296 A	Chain Cutting Knife-----	1
19A	36296 B	Chain Cutting Knife Guard -----	1
20	22801	Screw-----	1
21	22 KH	Screw-----	1
22	36283 C	Cylinder Hinged Spring Support Stud-----	1
23	36283 B	Spring -----	1
24	22585 C	Screw-----	1
24A	36251 K	Dowel Pin -----	2
25	36224 A	Throat Plate-----	1
26	36240	Stitch Tongue, marked "D"-----	1
27	22716 A	Screw -----	1
28	22562 A	Screw-----	3
29	36283 E	Cylinder Cover -----	1
30	98 A	Screw-----	8
31	531	Screw-----	1
31A	36284 E	Upper Lint Shield -----	1
31B	22798	Screw-----	1
32	36237 F	Bushing -----	1
33	36283 F	Gasket-----	1
34	35883 V	Gasket-----	1
35	22571 A	Plug Screw -----	1
36	667 D-16	Dowel Pin, straight -----	1
37	36284	Gasket-----	1
38	35876 U	Washer -----	3
39	22653 E-20	Screw-----	3
40	22596 D	Screw-----	1
41	36229 A-1	Cylinder Alignment Eccentric Pin-----	1
42	35884 D	Gasket-----	1
43	36284 C	Cylinder Cover and Oil Gauge, front -----	1
44	51-15 Blk.	Oil Gauge -----	1
45	J87 J	Screw-----	4
46	22539 N	Plug Screw -----	1
47	36249 A	Looper Shaft Bushing, front -----	1
48	22560 A	Screw-----	1
49	660-202	Oil Seal Ring -----	1
50	36297 H	Oil Drainage Screw-----	1
51	36286 A	Gasket-----	1
52	36286	Cylinder Side Cover -----	1
53	22766	Screw-----	4
54	531	Screw-----	2
55	87 A	Screw-----	3
56	36297 G	Oil Filter Assembly -----	1
57	36203	Edge Guide -----	1
58	22849	Screw -----	1

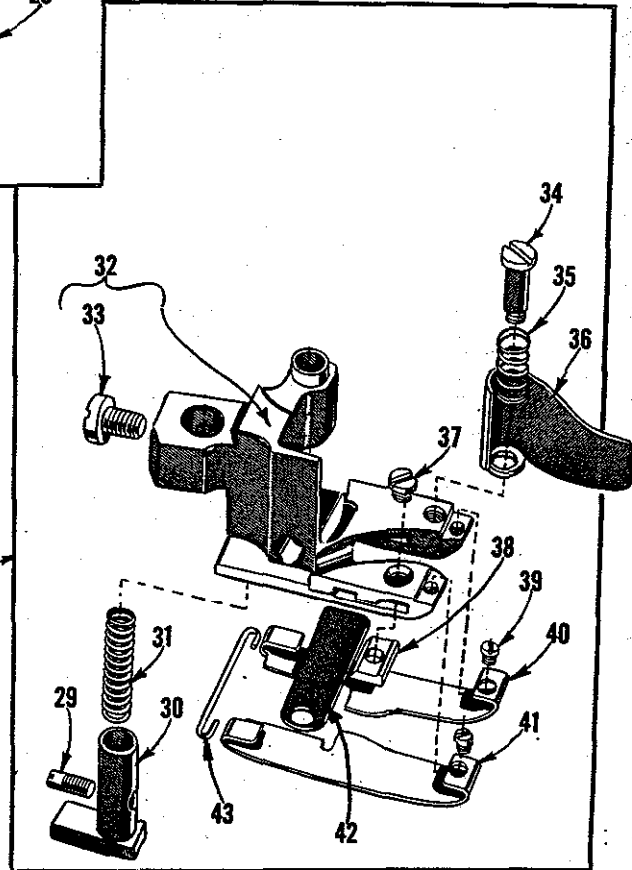
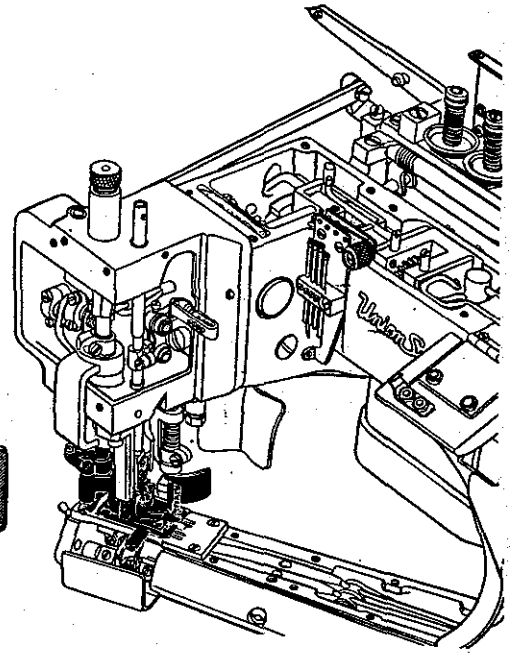
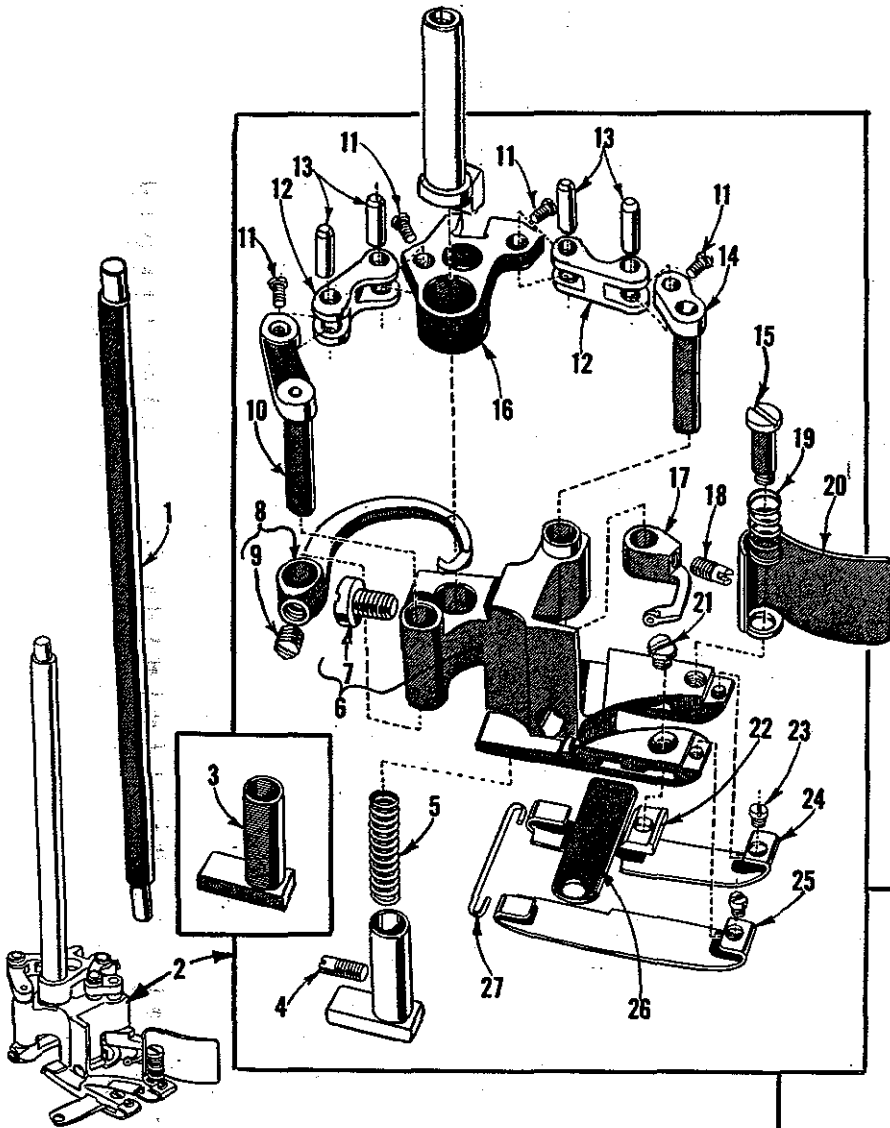

PRESSER BAR AND PRESSER FEET

<u>Ref. No.</u>	<u>Part No.</u>	<u>Description</u>	<u>Amt. Req.</u>
1	36278	Presser Bar - - - - -	1
2	36220 A	Presser Foot Assembly, for Styles 36200 A, AA, AK - - - - -	1
	36220	Presser Foot Assembly, for Styles 36200 B, AB - - - - -	1
3	36230 J	Yielding Section, marked "AP" - - - - -	1
4	22565 A	Screw - - - - -	1
5	36230 C	Spring - - - - -	1
6	36230 U	Presser Foot, for No. 36220 A, marked "BT" - - - - -	1
	36230	Presser Foot, for No. 36220, marked "S" - - - - -	1
7	94	Screw - - - - -	1
8	36251 F	Cover Thread Hook - - - - -	1
9	22562 A	Screw - - - - -	1
10	36251 H	Cover Thread Hook Driving Lever and Shaft - - - - -	1
11	22738 B	Screw - - - - -	1
12	36251 U	Link, for cover thread carrier and hook driving lever - - - - -	2
13	36251 K	Link Pin - - - - -	4
14	36251 G	Cover Thread Carrier Driving Lever and Shaft - - - - -	1
15	22731	Screw - - - - -	1
16	36251 L	Cover Thread Carrier and Hook Driving Segment - - - - -	1
17	36251 E	Cover Thread Carrier, marked "A" - - - - -	1
18	22565 A	Screw - - - - -	1
19	36279 D	Spring - - - - -	1
20	36279 C	Chip Guard - - - - -	1
21	150	Screw - - - - -	1
#22	36250 G	Stationary Knife Clamp, .326 inch (8.28 mm) Bright Finish - - - - -	1
#-	36250 B	Stationary Knife Clamp, .318 inch (8.08 mm) Black Finish - - - - -	1
23	22738 G	Screw - - - - -	2
24	*36232 D	Presser Foot Shoe, right, for No. 36220 A presser foot, See Page 39 - - - - -	1
25	*36231 D	Presser Foot Shoe, left, for No. 36220 A presser foot, See Page 39 - - - - -	1
	*36232 A	Presser Foot Shoe, right, for No. 36220 presser foot, See Page 39 - - - - -	1
	*36231 A	Presser Foot Shoe, left, for No. 36220 presser foot, See Page 39 - - - - -	1
26	36250	Stationary Knife - - - - -	1
27	36230 D	Shoe Holding Wire - - - - -	1
28	36220 B	Presser Foot Assembly, for Styles 36200 X, AX - - - - -	1
29	22565 A	Screw - - - - -	1
30	36230 J	Yielding Section, marked "AP" - - - - -	1
31	36230 C	Spring - - - - -	1
32	36230 G	Presser Foot, marked "W" - - - - -	1
33	94	Screw - - - - -	1
34	22731	Screw - - - - -	1
35	36279 D	Spring - - - - -	1
36	36279 H	Chip Guard - - - - -	1
37	150	Screw - - - - -	1
#38	36250 G	Stationary Knife Clamp, .326 inch (8.28 mm) Bright Finish - - - - -	1
#-	36250 B	Stationary Knife Clamp, .318 inch (8.08 mm) Black Finish - - - - -	1
39	22738 G	Screw - - - - -	2
40	36232 F	Presser Foot Shoe, right - - - - -	1
41	36231 F	Presser Foot Shoe, left - - - - -	1
42	36250	Stationary Knife - - - - -	1
43	36230 D	Shoe Holding Wire - - - - -	1

\* See Page 39 for other presser foot shoes available.

# When replacing the stationary knife clamp, order the clamp that has the same finish as the one being replaced.

PRESSER FOOT SHOES FOR 36200 PRESSER FEET

.012 inch  
thick

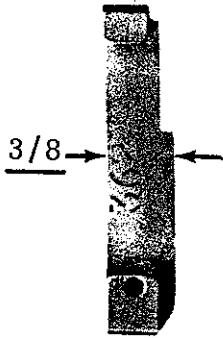

36231

.012 inch  
thick

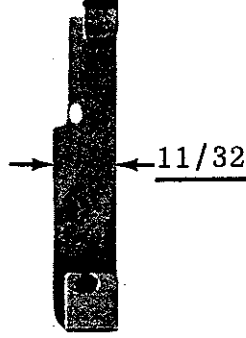

36232

Extended Toe

.012 inch  
thick

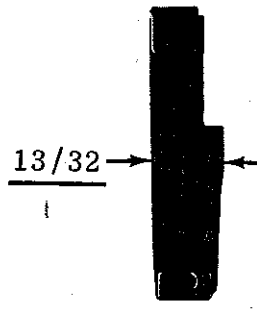

36231 A

.012 inch  
thick

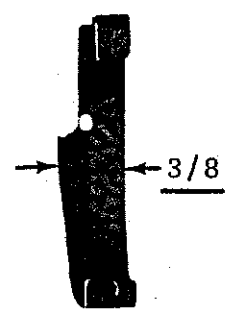

36232 A

.015 inch  
thick

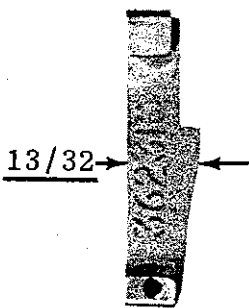

36231 C

.015 inch  
thick

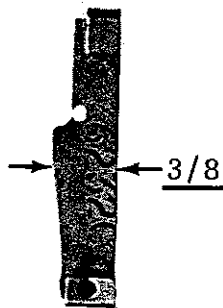

36232 C

.015 inch  
thick

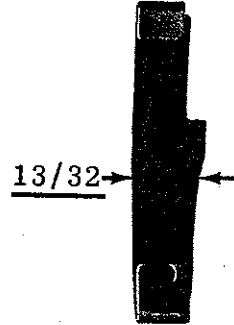

36231 B

.015 inch  
thick

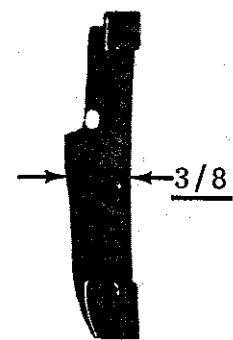

36232 B

Extended Toe

.015 inch  
thick

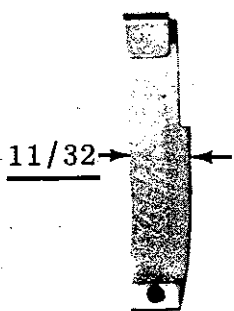

36231 D

.015 inch  
thick

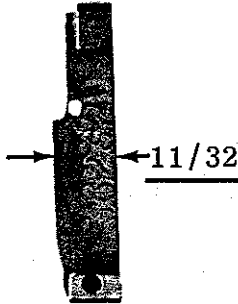

36232 D

.015 inch  
thick

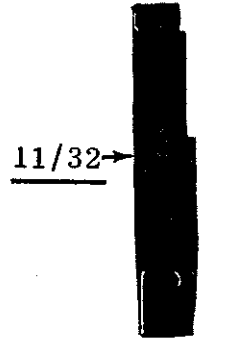

36231 E

.015 inch  
thick

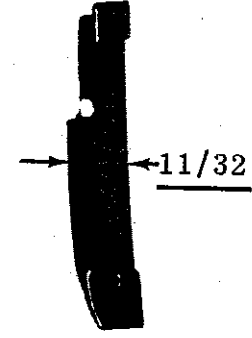

36232 E

Extended Toe

PRESSER FOOT SHOES FOR 36200 MACHINES

<u>Part No.</u>	<u>Description</u>	<u>Amt. Req.</u>
36231	Presser Foot Shoe, left, .012 inch thick, 3/8 inch wide, with extended toe-----	1
36232	Presser Foot Shoe, right, .012 inch thick, 11/32 inch wide, with extended toe, for light weight material. Used on 36220 ----	1
*36231 A	Presser Foot Shoe, left, .012 inch thick, 13/32 inch wide, short toe. On 36220 presser foot, furnished as standard on Styles 36200 B, AB-----	1
*36232 A	Presser Foot Shoe, right, .012 inch thick, 3/8 inch wide, short toe, for light weight material. On 36220 presser foot, furnished as standard on Styles 36200 B, AB-----	1
36231 B	Presser Foot Shoe, left, .015 inch thick, 13/32 inch wide, with extended toe-----	1
36232 B	Presser Foot Shoe, right, .015 inch thick, 3/8 inch wide, with extended toe, for medium and heavy weight material. Used on 36220 -----	1
*36231 C	Presser Foot Shoe, left, .015 inch thick, 13/32 inch wide, short toe. Furnished with Styles 36200 B, AB-----	1
*36232 C	Presser Foot Shoe, right, .015 inch thick, 3/8 inch wide, short toe, for medium and heavy weight material. Used on 36220. Furnished with Styles 36200 B, AB-----	1
†36231 D	Presser Foot Shoe, left, .015 inch thick, 11/32 inch wide, short toe. On 36220 A presser foot, furnished as standard on Styles 36200 A, AA-----	1
†36232 D	Presser Foot Shoe, right, .015 inch thick, 11/32 inch wide, short toe, for seaming over elastic. On 36220 A presser foot, furnished as standard on Styles 36200 A, AA-----	1
†36231 E	Presser Foot Shoe, left, .015 inch thick, 11/32 inch wide, with extended toe. Furnished with Styles 36200 A, AA-----	1
†36232 E	Presser Foot Shoe, right, .015 inch thick, 11/32 inch wide, with extended toe, for seaming over elastic. Used on 36220 A. Furnished with Styles 36200 A, AA-----	1

\*Furnished on Styles 36200 B or AB as standard, and if other shoes are required, order as extra send and charge.

†Furnished on Styles 36200 A or AA as standard, and if other shoes are required, order as extra send and charge.

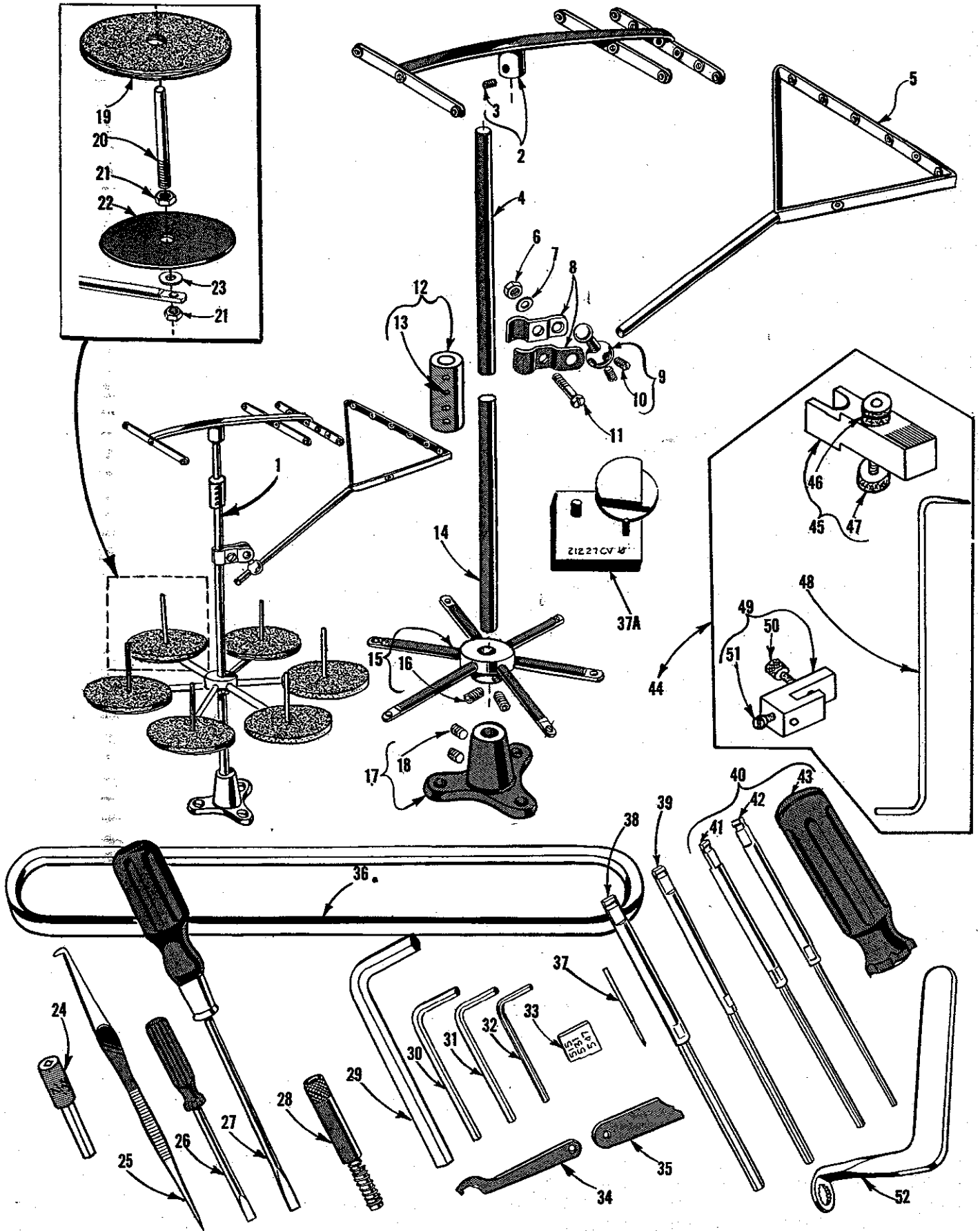



THREAD STAND AND ACCESSORIES

<u>Ref. No.</u>	<u>Part No.</u>	<u>Description</u>	<u>Amt. Req.</u>
1	21101 R-6	Thread Stand, complete, for Styles 36200 A, B -----	1
2	21114 H-6	Eyelet Support, for Styles 36200 A, B, AA, AB---	1
3	22651 CD-4	Screw -----	2
4	21104 B-11	Thread Stand Rod, for Styles 36200 A, B, AA, AB -----	1
5	21114 AK-6	Lead Eyelet, for Styles 36200 A, B, AA, AB-----	1
6	21104 H	Nut, for Styles 36200 A, B, AA, AB-----	1
7	652-16	Washer, for Styles 36200 A, B, AA, AB-----	1
8	21114 U	Lead Eyelet Ball Split Socket, for Styles 36200 A, B, AA, AB -----	2
9	21114 T	Lead Eyelet Socket Ball, for Styles 36200 A, B, AA, AB -----	1
10	22651 CD-4	Screw -----	2
11	22810	Screw, for Styles 36200 A, B, AA, AB -----	1
12	21127	Support Rod Coupling, for Styles 36200 A, B, AA, AB -----	1
13	22651 CD-3	Screw -----	4
14	21104 B-24	Thread Stand Rod, for Styles 36200 A, B, AA, AB -----	1
15	21114 D-6	Spool Seat Support, for Styles 36200 A, B, AA, AB -----	1
16	22651 CD-5	Screw -----	2
17	21114 A	Thread Stand Base, for Styles 36200 A, B -----	1
18	22651 CD-3	Screw -----	1
19	21104 V	Pad, for Styles 36200 A, B, AA, AB -----	6
20	21114 W	Spool Pin, for Styles 36200 A, B, AA, AB -----	6
21	258 A	Nut, for Styles 36200 A, B, AA, AB-----	12
22	21114	Spool Seat Disc, for Styles 36200 A, B, AA, AB--	6
23	652-16	Washer, for Styles 36200 A, B, AA, AB-----	6
*24	21388 AW	Socket, with 7/32 inch hexagon bit, for aligning cylinder -----	1
	21388 AX	Socket, with 1/4 inch hexagon bit, for aligning cylinder on late model machines -----	1
25	660-272	Thread Tweezers-----	1
26	21207 A	Screwdriver -----	1
27	21201	Screwdriver -----	1
*28	21227 BV	Looper Avoid Gauge-----	1
29	WR62	Wrench, 5/16 inch hexagon, for Styles 36200 A, B---	1
30	WR57	Wrench, 5/32 inch hexagon -----	1
31	WR56	Wrench, 1/8 inch hexagon, for Styles 36200 A, B, AA, AB -----	1
32	WR64	Wrench, 3/32 inch hexagon-----	1
†-	WR69	Wrench, 9/64 inch hexagon, for Styles 36200 AA, AB -----	1
*33	21227 BU	Needle Height Gauge -----	1
*34	21388 Y	Spanner Wrench -----	1
*35	21225 F-3/16	Looper Gauge, 3/16 inch -----	1
36	21261 M-210	Vee Belt, 21 inch outside circumference, for Styles 36200 A, B -----	1
*37	699 S	Test Pin (for use with 21227 BU)-----	1
*37A	21227 CV	Cover Thread Hook Gauge -----	1
†	23441 P	Swing-out Edge Guide Assembly-----	1
38 to 52		See following page	

\* Tools and accessories which are not furnished with machines, but which may be purchased separately and should prove helpful in the operation and maintenance of the machine.

† Not shown by picture.

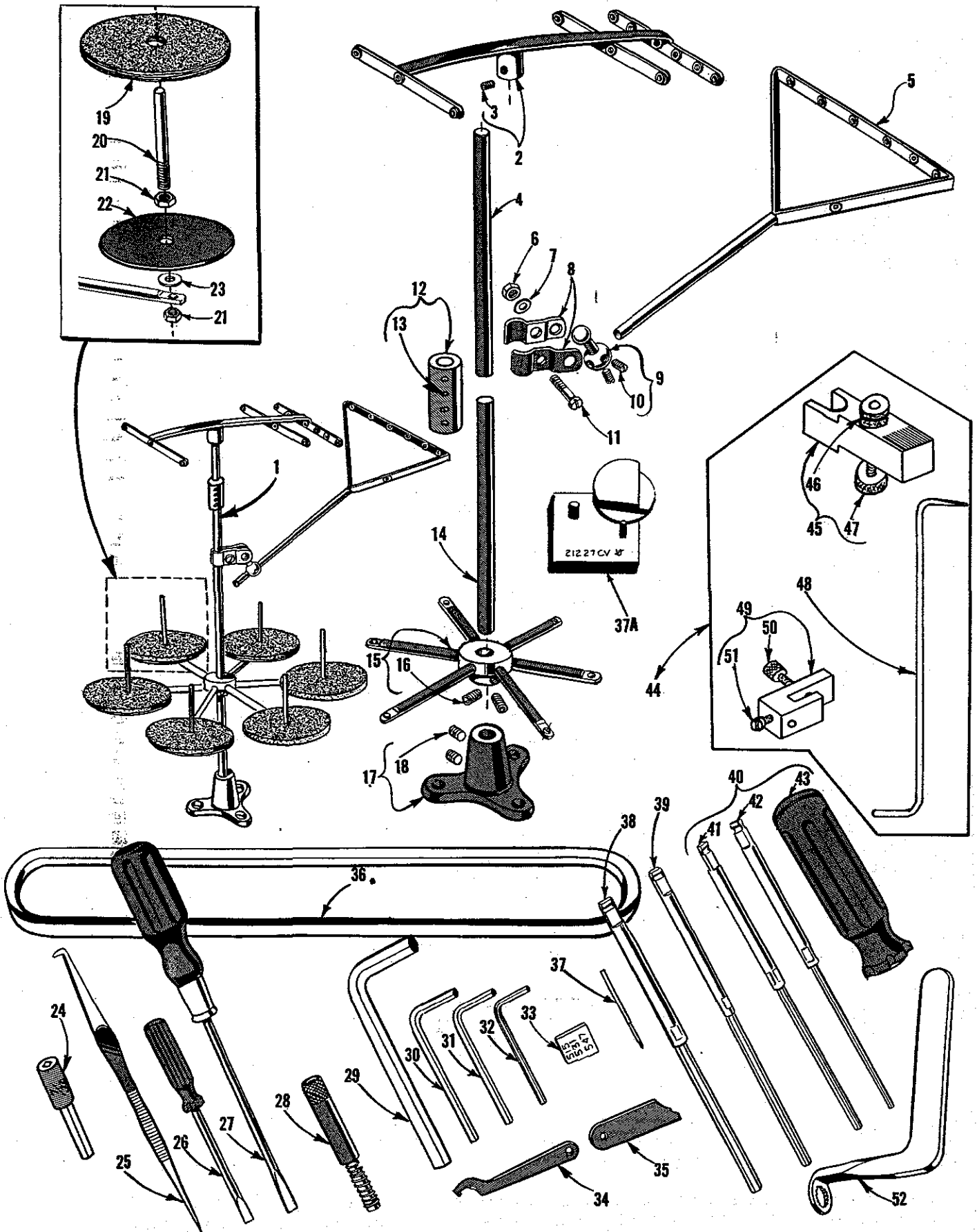

THREAD STAND AND ACCESSORIES

<u>Ref. No.</u>	<u>Part No.</u>	<u>Description</u>	<u>Amt. Req.</u>
	1 to 37	See preceding page	
* 38	21209 F	Hexagonal Socket Bit, 3/16 inch, for use with handle No. 21209 G -----	1
* 39	21209 E	Hexagonal Socket Bit, 5/32 inch, for use with handle No. 21209 G -----	1
*†-	21209 K	Hexagonal Socket Bit, 7/64 inch, for use with handle No. 21209 G -----	1
*†-	21209 L	Hexagon Socket Bit, 9/64 inch, for use with handle No. 21209 G -----	1
* 40	21209 D	Screwdriver, for socket head screw, 3/32 inch and 1/8 inch hexagonal -----	1
* 41	21209 J	Hexagonal Socket Bit, 1/8 inch -----	1
* 42	21209 H	Hexagonal Socket Bit, 3/32 inch -----	1
* 43	21209 G	Handle -----	1
* 44	21227 CG	Synchronizing Gauge, looper and needle timing -----	1
* 45	21227 CH	Needle Setting Block -----	1
* 46	1347 A	Nut -----	1
* 47	14087	Thumbscrew -----	1
* 48	21227 CK	Synchronizing Gauge Rod -----	1
* 49	21227 CJ	Looper Clamp and Height Gauge -----	1
* 50	22703 A	Screw -----	1
* 51	22738	Screw -----	1
* 52	21388 AY	Wrench, for 3/16 inch square nut on No. 35851 K -----	1
†	21104 Y-18	Thread Stand Support Rod, 18 inches long, for Styles 36200 AA, AB -----	1
†	21233 E	Thread Stand Rod Connection, for Styles 36200 AA, AB -----	1
†	1421	Handwheel, for Styles 36200 AA, AB -----	1
†	1421 A	Handwheel Stud, for Styles 36200 AA, AB -----	1
†	22807	Screw, for handwheel, for Styles 36200 AA, AB -----	3
†	21227 AR	Torque Rod, for Styles 36200 AA, AB -----	1
†	21233 K	Switch Bracket, for Styles 36200 AA, AB -----	1
†	22640 M-32	Screw, for 21233 K, for Styles 36200 AA, AB -----	2
†	652 B-24	Lockwasher, for 22640 M-32, for Styles 36200 AA, AB -----	2
†	22635	Screw, for 21233 K, for Styles 36200 AA, AB -----	2
†	652 B-16	Lockwasher, for 22635, for Styles 36200 AA, AB -----	2
†	651-16	Nut, for 22635, for Styles 36200 AA, AB -----	2
†	650 X-20	Carriage Bolt, for motor, for Styles 36200 AA, AB -----	3
*†	21227 CT	Kit of Gauges, includes Nos. 21227 BV, 21227 CG, 21227 CN -----	1
*†	21227 CN	Looper Travel Gauge, includes Nos. 21227 CM, 21227 CS -----	1
*†	21227 CM	Looper Travel Gauge Pointer -----	1
*†	21227 CS	Looper Travel Gauge Plate -----	1
*†	21227 CU	Looper Alignment Gauge -----	1
†	21661	Knee Press Rock Shaft, for Styles 36200 A, B -----	1
†	21663	Knee Press Plate Rod, for Styles 36200 A, B -----	1
†	21661 D	Knee Press Rock Shaft Stop, for Styles 36200 A, B -----	1
†	9271	Intermediate Rock Shaft Collar, for Styles 36200 A, B -----	1
†	21663 E	Lifter Link Rod, for Styles 36200 A, B -----	1
†	421 D-28	Lifter Lever Chain, for Styles 36200 A, B -----	1
†	21662 Y	Lifter Lever Link, for Styles 36200 A, B -----	1
†	660-254 C	Retaining Ring, for Styles 36200 A, B -----	2
†	21665	Knee Press Rod Connection, for Styles 36200 A, B -----	2
†	21662 Z	Knee Press Bracket, for Styles 36200 A, B -----	1
†	21662 AA	Lifter Lever Torsion Spring, for Styles 36200 A, B -----	1
†	28604 R	Can of Oil, 16 fluid ounces, Spec. 174 -----	1
†	660-457	Dust Cover, for Styles 36200 A, B -----	1

\* Tools and accessories which are not furnished with machines, but which may be purchased separately and should prove helpful in the operation and maintenance of the machine.

† Not shown by picture.

PL-506

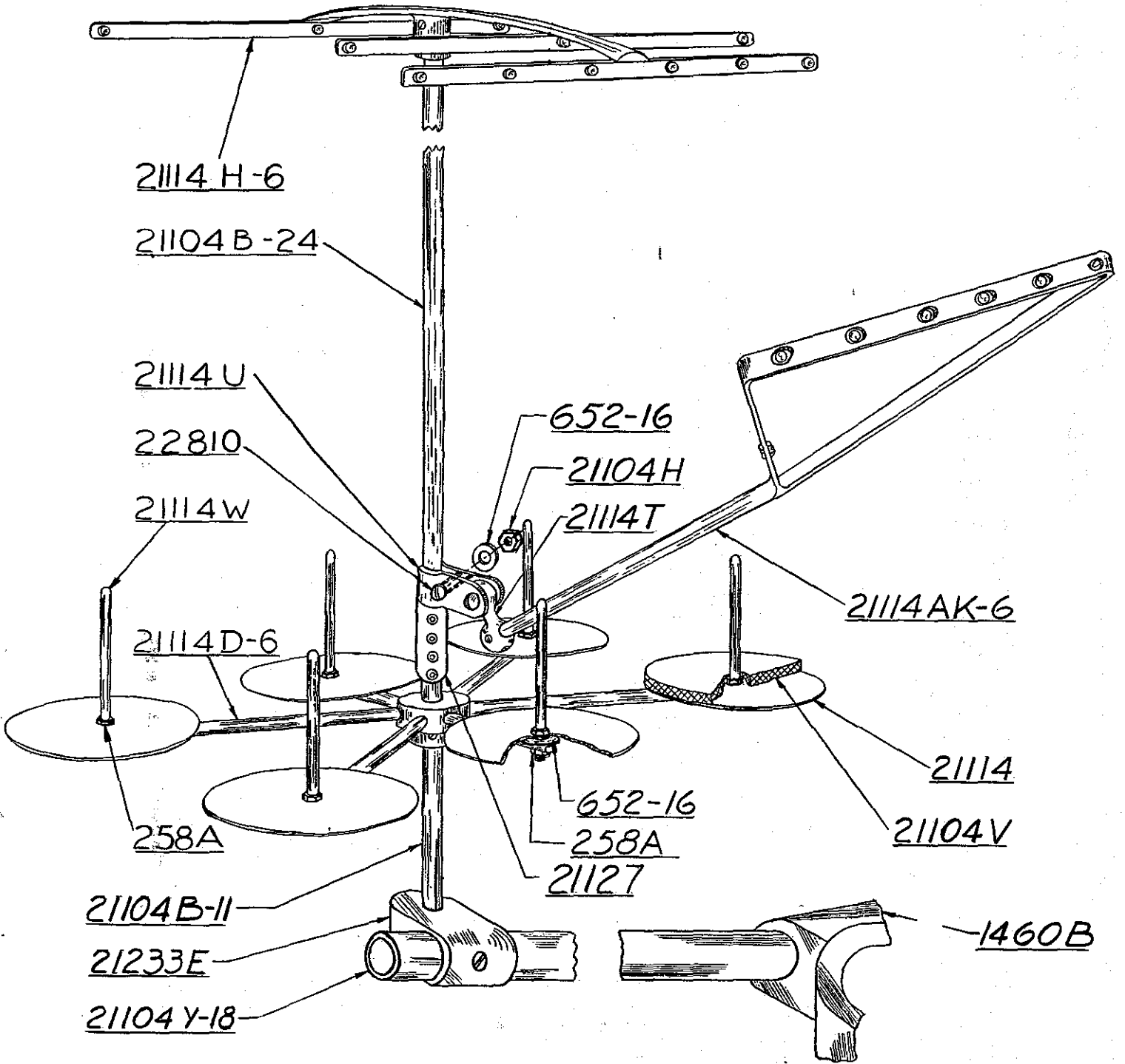

THREAD STAND FOR PEDESTAL INSTALLATION

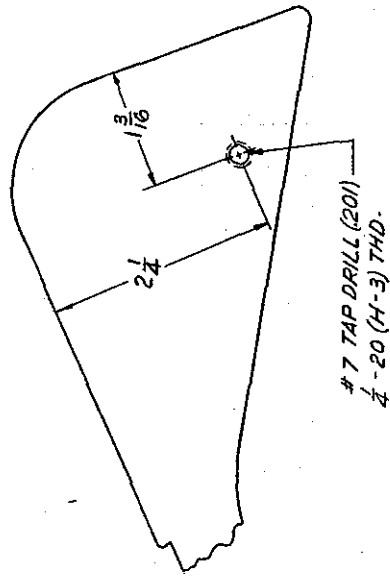
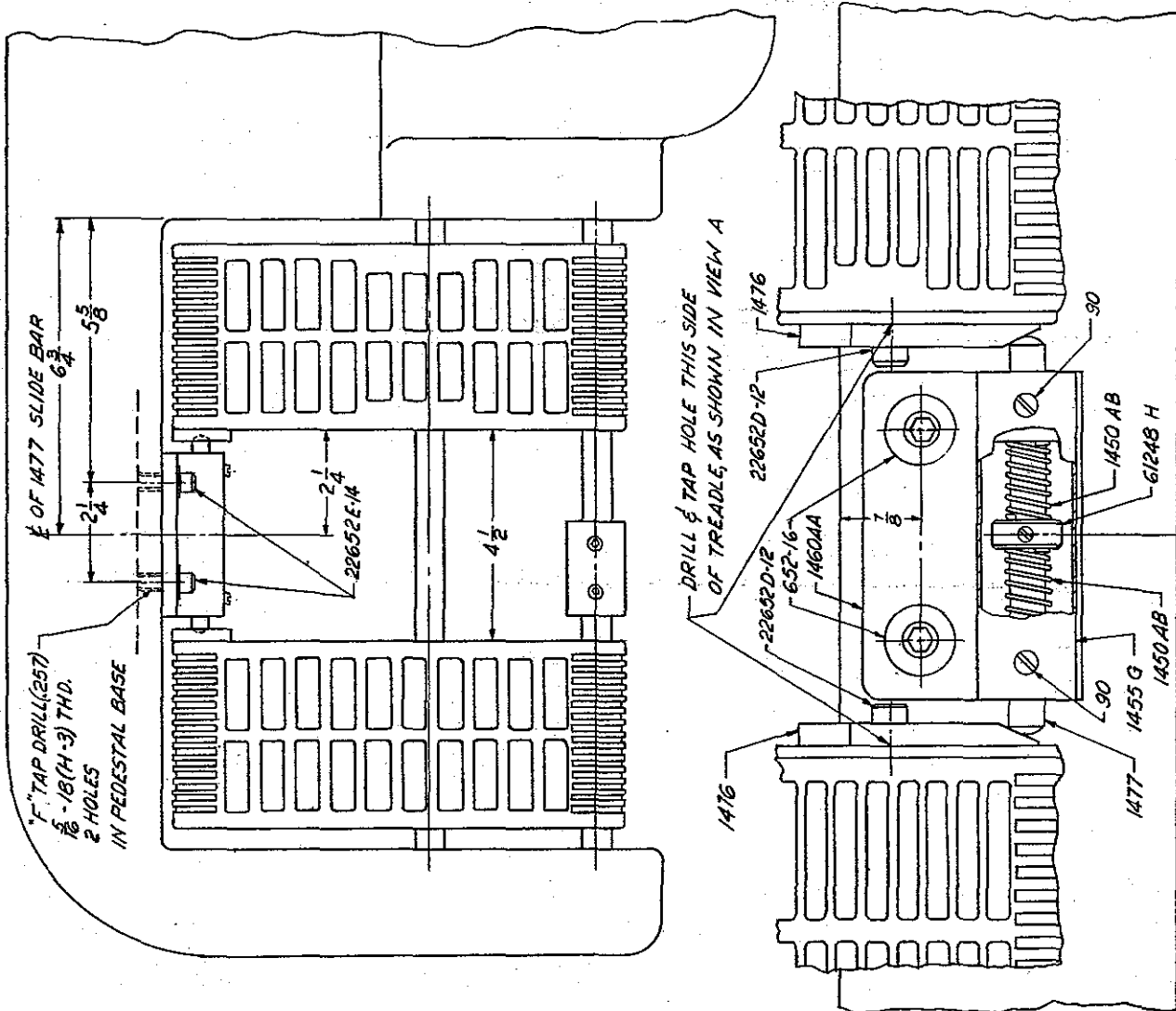

V I E W A

THIS PLANOGRAPH SHOWS THE METHOD FOR CONVERTING THE 1400K PEDESTAL TO USE 29480 DZ TREADLE INTER-LOCK MECHANISM KIT.

NUMERICAL INDEX OF PARTS

Part No.	Page No.	Part No.	Page No.	Part No.	Page No.	Part No.	Page No.
18.....	29,31,33	660-261.....	27	21388 AW.....	41	22747.....	31,33
20.....	33	660-272.....	41	21388 AX.....	41	22759 A.....	27
CL21.....	21	660-275.....	19	21388 AY.....	43	22766.....	23,35
22 KH.....	21,35	660-302.....	19	21661.....	43	22767 A.....	33
25 S.....	19	660-311.....	33	21661 D.....	43	22768 B.....	21
28.....	27	660-457.....	43	21662 Y.....	43	22777 B.....	27
28 A.....	27	664 F.....	27	21662 Z.....	43	22784 F.....	25
28 C.....	21	666-96.....	19,21	21662 AA.....	43	22791 D.....	21
36 G.....	33	666-128.....	19	21663.....	43	22791 E.....	35
50-537 Blk.....	21	667 D.....	35	21663 E.....	43	22795 B.....	33
51-15 Blk.....	35	699 S.....	41	21665.....	43	22797.....	23
51-120 Blk.....	19	1096 B.....	33	21705.....	19	22798.....	35
WR56.....	41	1347 A.....	43	21756 G.....	23	22799 B.....	21
WR57.....	41	1421.....	43	22504 C.....	29	22799 N.....	33
WR62.....	41	1421 A.....	43	22513.....	27	22801.....	23,35
WR64.....	41	4761.....	33	22516 A.....	21	22807.....	43
WR69.....	41	6042 A.....	23,27,31	22517.....	25	22810.....	41
69 H.....	21	9271.....	43	22519 F.....	23	22829.....	21
73 A.....	21	12538.....	25	22524.....	27	22839.....	21
73 C.....	21,35	12865.....	33	22528.....	29	22839 D.....	25
77.....	23,31,33	12934 A.....	21,33	22539 M.....	21	22845 M.....	29
86.....	25	14087.....	43	22539 N.....	35	22849.....	35
87 A.....	35	15037 A.....	33	22539 T.....	21	22881 A.....	27
J87 J.....	35	21101 R.....	41	22560 A.....	27,35	22882 A.....	19
87 U.....	29	21104 B.....	41	22562 A.....	23,33,35,		
88.....	33	21104 H.....	41		37	22894 C.....	19
88 B.....	25	21104 V.....	41	22564.....	23	22894 E.....	23
89.....	23	21104 Y.....	43	22564 B.....	21	22894 H.....	23
90.....	21,23	21114.....	41	22564 D.....	33	22894 J.....	23,25
93.....	21	21114 A.....	41	22565 A.....	37	22894 K.....	23
93 A.....	21	21114 D.....	41	22569 B.....	21	22894 V.....	19
94.....	25,37	21114 H.....	41	22569 C.....	19	22894 W.....	23,29,31
97 A.....	29,33	21114 T.....	41	22571 A.....	19,35		35
98 A.....	35	21114 U.....	41	22571 B.....	23	22894 X.....	19,23,33
107.....	25	21114 W.....	41	22572 B.....	33	23441 P.....	41
108.....	25	21114 AK.....	41	22574.....	19	28604 R.....	43
109.....	25	21127.....	41	22580.....	23	29101 J.....	23,31
118 GKS.....	27	21201.....	41	22585.....	33	29103 T.....	23,29
150.....	37	21207 A.....	41	22585 A.....	23,33	29478 CS.....	29
255.....	25	21209 D.....	43	22585 C.....	25,35	29478 CT.....	31
258.....	31	21209 E.....	43	22587 B.....	23	29478 CU.....	33
258 A.....	25,33,41	21209 F.....	43	22587 E.....	23,29,31	29478 CZ.....	35
269.....	29,31,33	21209 G.....	43	22587 H.....	29	29478 DM.....	31
318.....	27	21209 H.....	43	22593.....	21	29478 DR.....	33
421 D-28.....	43	21209 J.....	43	22596 B.....	23	29480 CK.....	19
531.....	23,35	21209 K.....	43	22596 D.....	21,35	33174 B.....	29
538.....	35	21209 L.....	43	22635.....	43	35751 G.....	33
604.....	33	21225 F.....	41	22640 M.....	43	35760 D.....	21
605 A.....	33	21227 AR.....	43	22650 AE.....	19,23	35761 D.....	21
650 X.....	43	21227 BU.....	41	22651 CD.....	41	35763.....	23
651-16.....	41,43	21227 BV.....	41	22652 A.....	33	35763 F.....	23
651 B.....	19	21227 CG.....	43	22652 F.....	19	35763 G.....	23
652-16.....	41	21227 CH.....	43	22653 B.....	27	35766 B.....	31
652 B.....	43	21227 CJ.....	43	22653 E.....	35	35767.....	27
652 C-9.....	33	21227 CK.....	43	22703 A.....	43	35781 D.....	21
652 K-24.....	35	21227 CM.....	43	22711.....	21,31	35815 A.....	23
660-161.....	19	21227 CN.....	43	22716 A.....	35	35817 E.....	27
660-202.....	23,33,35	21227 CS.....	43	22729.....	23	35842 J.....	31
660-206.....	31	21227 CT.....	43	22729 C.....	31,33	35846.....	31
660-207.....	23,29,31	21227 CU.....	43	22729 D.....	33	35846 B.....	31
660-215.....	33	21227 CV.....	41	22731.....	37	35850 D.....	35
660-219 D.....	33	21233 E.....	43	22731.....	37	35851 K.....	31
660-219 P.....	23,33	21233 K.....	43	22733 B.....	21	35851 L.....	33
660-220.....	23,35	21261 M.....	19,41	22738.....	43	35851 M.....	31
660-221.....	33	21371 UE.....	19	22738 B.....	37	35859 C.....	27
660-254 C.....	25,43	21388 Y.....	41	22738 G.....	37	35859 D.....	27
				22738 H.....	27	35861 D.....	23

NOTE: Only the basic part numbers are shown in the index. For various gauges, capacities, etc. available, refer to the listings on pages indicated.

NUMERICAL INDEX OF PARTS

Part No.	Page No.	Part No.	Page No.	Part No.	Page No.	Part No.	Page No.
35817 E.....	27	36229 B.....	25	36251 N.....	23	36284 E.....	35
35842 J.....	31	36230.....	37	36251 P.....	33	36286.....	35
35846.....	31	36230 C.....	37	36251 U.....	37	36286 A.....	35
35846 B.....	31	36230 D.....	37	36253 A.....	33	36289.....	25
35850 E.....	35	36230 G.....	37	36253 B.....	33	36289 A.....	27
35851 K.....	31	36230 J.....	37	36253 G.....	33	36289 B.....	25
35851 L.....	33	36230 U.....	37	36253 H.....	33	36290.....	21
35851 M.....	31	36231.....	39	36253 J.....	33	36290 A.....	21
35859 D.....	27	36231 A.....	37,39	36256.....	21	36290 B.....	21
35859 J.....	27	36231 B.....	39	36256 A.....	21	36292 K.....	25
35861 D.....	23	36231 C.....	39	36256 B.....	35	36292 M.....	25
35862.....	23	36231 D.....	39	36260.....	21	36292 N.....	25
35866.....	31	36231 E.....	39	36261.....	33	36293 A.....	19
35876 U.....	35	36231 F.....	37,39	36261 A.....	23	36293 B.....	21
35880 M.....	27	36231 N.....	37,39	36263.....	23	36293 E.....	21
35883 G.....	35	36231 P.....	39	36264 A.....	27	36294 B.....	27
35883 V.....	35	36232.....	39	36264 B.....	25	36294 C.....	27
35884 D.....	35	36232 A.....	37,39	36264 D.....	23	36295 F.....	19
35884 K.....	29	36232 B.....	39	36270.....	33	36295 G.....	19
35887 M.....	21	36232 C.....	39	36271.....	21	36295 H.....	19
35887 R.....	21	36232 D.....	39	36271 A.....	21	36295 J.....	19
35887 V.....	21	36232 E.....	39	36271 D.....	21	36295 V.....	19
35887 X.....	21	36232 F.....	37,39	36271 E.....	21	36295 W.....	19
35887 Z.....	21	36232 N.....	37,39	36271 F.....	21	36295 Y.....	19
35887 AD.....	21	36232 P.....	39	36273 A.....	33	36295 Z.....	19
35887 AE.....	21	36234 C.....	29	36273 C.....	33	36295 AA.....	19
35888 N.....	21	36234 D.....	29	36273 D.....	33	36295 AB.....	19
35888 P.....	21	36234 E.....	29	36273 F.....	33	36295 AC.....	19
35889 H.....	21	36234 F.....	29	36273 G.....	33	36295 AD.....	19
35890 E.....	21	36234 G.....	29	36273 J.....	33	36295 AE.....	19
35892-6.....	25	36236.....	31	36273 K.....	33	36296 A.....	35
35894 J.....	23	36236 A.....	29,31	36273 M.....	33	36296 B.....	35
35894 L.....	23	36236 B.....	31	36273 N.....	33	36297 A.....	23
35895 R.....	19	36236 C.....	31	36278.....	37	36297 E.....	23
35895 X.....	23	36236 D.....	31	36278 A.....	25	36297 G.....	35
35895 Y.....	23	36236 E.....	29	36278 C.....	33	36297 H.....	35
35897 BN.....	23	36236 F.....	29	36278 D.....	27	36297 J.....	23
35897 BP.....	23	36236 G.....	29	36278 E.....	27	39145 A.....	33
35897 BR.....	23	36236 H.....	29,31	36278 F.....	27	39593 C.....	21
35897 BU.....	23	36236 J.....	31	36278 G.....	27	41071 G.....	21
35897 BV.....	23	36236 K.....	31	36278 H.....	27	41255 B.....	31,33
35897 BW.....	23	36237.....	29	36278 J.....	33	41394 A.....	21
35897 BY.....	23	36237 A.....	29	36279.....	27	43246.....	31
36203.....	35	36237 E.....	35	36279 A.....	27	51054.....	23
36204.....	21	36237 F.....	35	36279 B.....	27	51254 J.....	23
36204 A.....	21	36237 G.....	35	36279 C.....	37	51259.....	27
36205 A.....	29	36237 H.....	35	36279 D.....	37	51292 F-2.....	25
36205 B.....	29	36237 J.....	35	36279 E.....	27	51292 F-4.....	25
36205 C.....	29	36238.....	35	36279 G.....	27	51292 F-5.....	25
36205 D.....	29	36238 E.....	35	36279 H.....	37	51292 F-8.....	37
36208 A.....	33	36240.....	35	36280 A.....	25	51493 E.....	23
36210.....	33	36244.....	29	36280 B.....	21	52336.....	33
36211.....	27	36244 A.....	29	36280 C.....	25	52841 H.....	33
36218.....	27	36248.....	33	36280 D.....	25	52848 B.....	33
36220.....	37	36249.....	33	36280 F.....	25	52848 C.....	33
36220 A.....	37	36249 A.....	35	36280 G.....	25	52958 F.....	21
36220 B.....	37	36250.....	37	36280 J.....	25	56341 F.....	31
36221 B.....	23	36250 B.....	37	36280 K.....	25	56354 A.....	23
36222 A.....	23	36250 G.....	37	36280 L.....	25	56390 E.....	21
36222 C.....	23	36251 B.....	33	36280 M.....	25	60078 Z.....	35
36223.....	23	36251 C.....	33	36280 N.....	25	61248 H.....	45
36223 A.....	23	36251 D.....	27	36281.....	21	61321 J.....	19
36224 A.....	35	36251 E.....	37	36283 A.....	35	61321 L.....	19
36225.....	29	36251 F.....	37	36283 B.....	35	62238 A.....	29,31
36226 A.....	29	36251 G.....	37	36283 C.....	35	62271 B.....	21
36226 B.....	29	36251 H.....	37	36283 E.....	35	80265.....	23
36226 C.....	29	36251 K.....	35,37	36283 F.....	35		
36226 D.....	29	36251 L.....	37	36284.....	35		
36229 A-1.....	35	36251 M.....	23	36284 C.....	35		

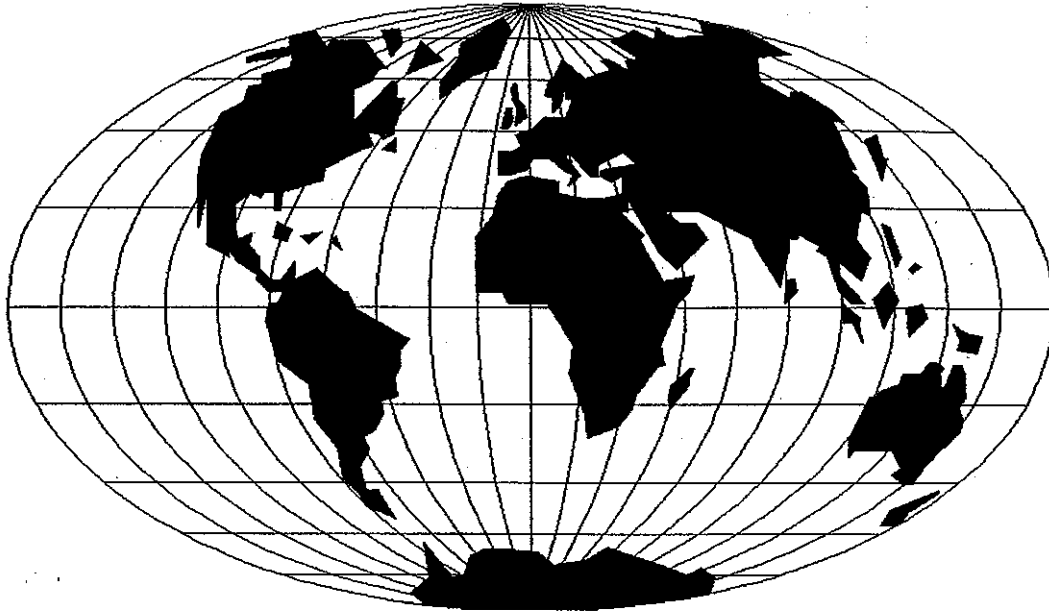

## WORLDWIDE SALES AND SERVICE

Union Special Corporation maintains sales and service facilities throughout the world. These offices will aid you in the selection of the right sewing equipment for your particular operation. Union Special Corporation representatives and service technicians are factory trained and are able to serve your needs promptly and efficiently. Whatever your location, there is a qualified representative to serve you.

---

Corporate Office: One Union Special Plaza  
Huntley, IL 60142  
Phone: 847•669•5101  
Fax: 847•669•4454

European Distribution Center: Union Special GmbH  
Raiffeisenstrasse 3  
D-71696 Möglingen, Germany  
Tel: 49•07141•247•0  
Fax: 49•07141•247•100

Brussels, Belgium  
Charlotte, N.C.  
Hong Kong, China  
Huntley, IL  
Leicester, England  
Lille, France  
Miami, FL  
Milan, Italy  
Möglingen, Germany  
Montreal, Quebec  
Osaka, Japan  
Santa Fe Springs, CA  
Suwanee, GA  
Wayne, NJ

Other Representatives throughout  
all parts of the world.



*Union Special*  
INDUSTRIAL SEWING EQUIPMENT